

REVISIONS				
REV.	DESCRIPTION	BY	DATE	ECR/ECN#

COMMON NAME: FSWV
FREE STANDING WEB VIEWER
SHOWN IN CART MOUNTED CONFIGURATION

ELEVATION CONTROL HAND WHEEL
 REPLACE BY MOTOR OPTIONAL

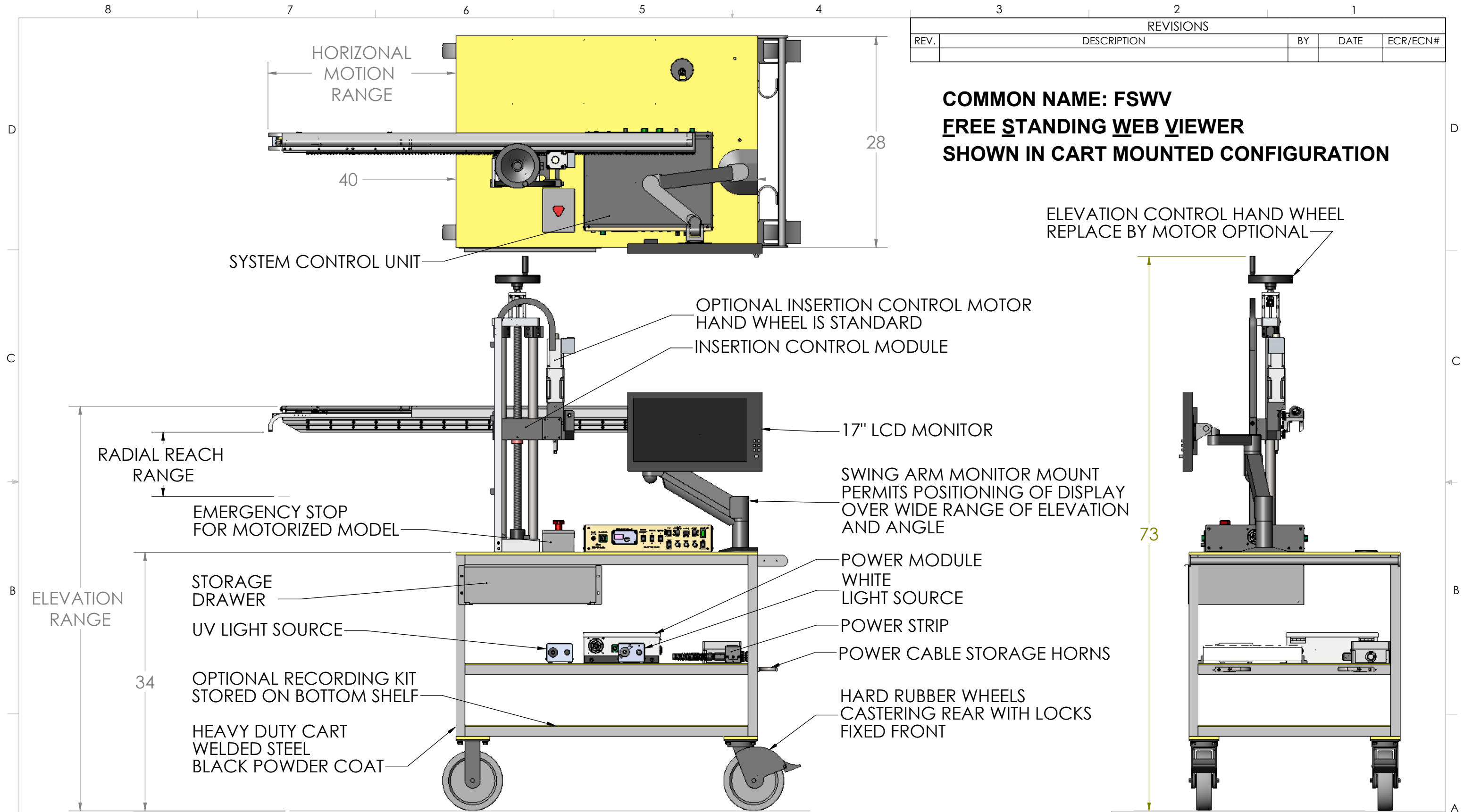

FREE STANDING WEBVIEWER CART MOUNTED
 ELEVATION RANGE 38" TO 58"
 RADIAL REACH = 10"
 HORIZONTAL MOTION RANGE 0 TO 38"
 NOTE: UMBILICAL AND POWER CABLES NOT SHOWN
 CART MOUNTED CONFIGURATION IS OPTIONAL

INFORMATION ONLY - SUBJECT TO CHANGE

SHEET 1 OF 1
 © 2023 InterTest Inc.

PROPRIETARY AND CONFIDENTIAL
 THE INFORMATION CONTAINED IN THIS
 DRAWING IS THE SOLE PROPERTY OF
 INTERTEST, INC. ANY REPRODUCTION
 IN PART OR AS A WHOLE WITHOUT THE
 WRITTEN PERMISSION OF INTERTEST, INC.
 IS PROHIBITED.

UNLESS OTHERWISE SPECIFIED DIMENSIONS ARE IN INCHES		
.XX ±.02	.XXX ±.005	ANGLES ±0° 30'
MATERIAL AS NOTED		
FINISH		
APPROVALS	DATE	
DRAWN WJH	10-5-2023	
CHECKED		
CAD FILE:	SCALE	
	1:12	

FSWV HD CART MOUNTED INFORMATION		REV.
SIZE B	129700 FSWV HD INFO	-