

*“Precise, reliable,
easy to use and based
on the Industry Standard
GrindoSonic® Technology for
Non-Destructive Testing.”*

GrindoSonic® MK7



- Shop floor Quality Control
- Non-Destructive Testing (E- and G-Modulus, Poisson,...)
- In depth materials analysis (for R&D)

GrindoSonic
THE IMPULSE EXCITATION TECHNIQUE

GrindoSonic®: measuring 'ELASTIC' properties of materials

Elasticity

Deformation under externally applied load and return to original shape once the load is removed.

Strain (deformation)

Linearly proportional to applied stress (load) - the material is linearly elastic.

Robert Hooke's law: $\frac{\text{Stress}}{\text{Strain}} = \text{constant} \sim \text{Modulus of elasticity} = \text{E-Modulus}$

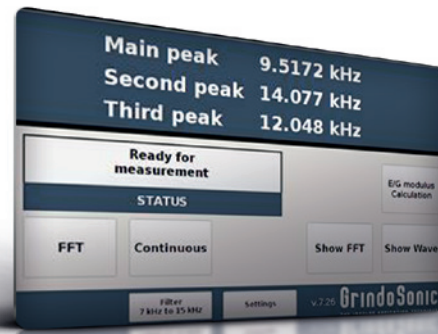
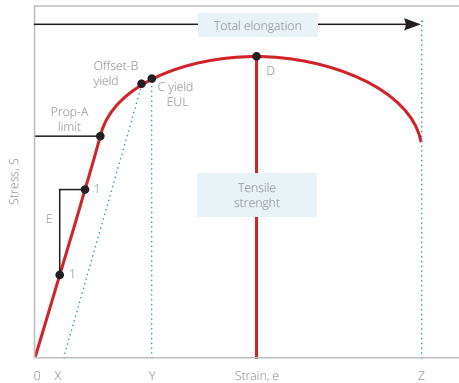

In engineering, structures are designed to function at low stress levels to avoid permanent deformation.

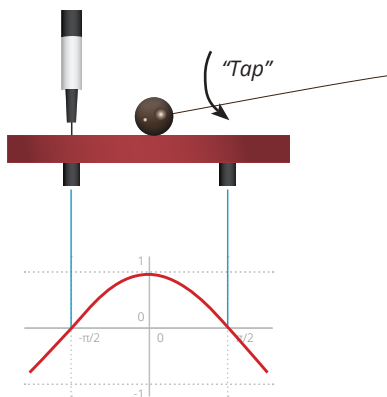

Piezo-electric probe

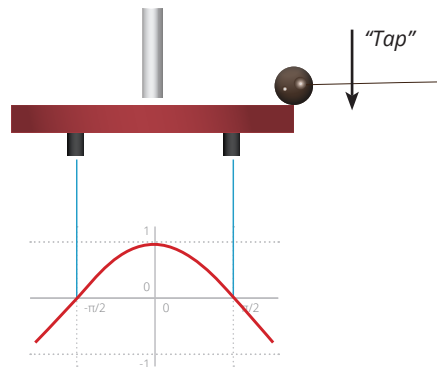

Acoustic vibration measurement

Measurement technique, "Tap & Read"

- Measuring with GrindoSonic is surprisingly **simple**
- As soon as switched on, it is **ready** to operate
- The measurement itself is executed in just a few seconds, just Tap and Read

The GrindoSonic® has been designed to measure elastic properties of a wide range of materials.

Impulse Excitation Technique:

- The sample is subjected to a small **deformation** by means of a **mechanical impulse**
- Immediately, the object will act as a spring-mass system and produce a **decaying mechanical vibration**
- The **frequency** of this vibration depends on the **mass** of the object and its **stiffness**, which is determined by its **shape** and **dimensions** and the **modulus of elasticity** of the material
- Speed of wave measurement as material parameter
- GrindoSonic analyses the damping of the natural frequency and displays the value in 2 options (Logarithmic Decrement or Specific Damping Capacity (SDC))

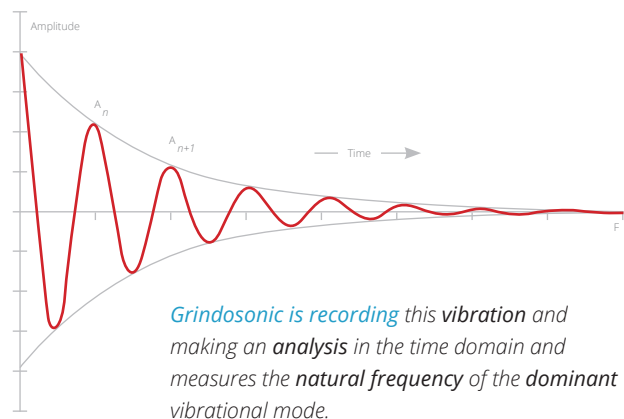

FFT “Fast Fourier Transform” / Spectroscope

- Spectrum visualization between 20 Hz and 150 KHz
- Extreme high resolution of up to 1 ppm (1 in 1.000.000)
- Noise level adjustment
- Sample size and frequency adjustment
- Normalisation function to rescale low energy

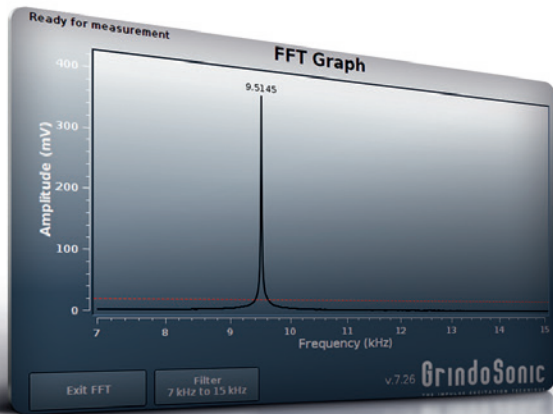

E-G calculation

- Automatic calculation of E- and G-Modulus
- Measurement of honing stones, bars, cylinders, grinding wheels, ...
- USB memory stick connection
- Full spectrum data storage (.csv)



Wave form visualization / oscilloscope

- Adjustment in scale and time
- Full wave form storage (.csv)
- Time domain visualization of measurements

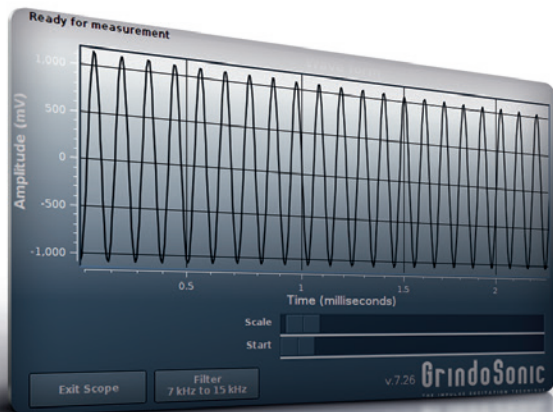

Filter band instrumentation

- Eight high order hardware analog precision band pass filters
- Software filter band selection

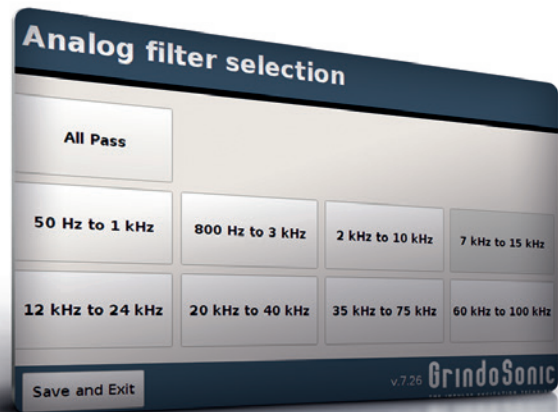

“Universal instrument for industrial Quality Control, materials characterization and research purposes.”

The GrindaSonic system is based on the Impulse Excitation Technique, which has been approved by international standards such as ASTM E1876, ASTM C1259, ASTM C1548, ASTM C215, EN 843-2, EN ISO12680-1, EN 14146 and many more.

GrindoSonic® MK7

GrindoSonic® MK7, the instrument for Non-Destructive measurements of Material Characteristics based on Impulse Excitation Technique (IET).



The core apparatus measures various natural vibration frequencies on a wide range of test objects through the use of the Impulse Excitation Technique (IET).

Highlights

- Non-Destructive measurements of elastic properties of materials
- Extremely rapid and simple: just a light tap is needed and the result is displayed within a fraction of a second
- Measurements of E- and G-Modulus and Poisson's ratio
- An alternative to destructive testing as excellent correlations exist between breaking load and natural frequency
- Production process monitoring for launch and QA-QC
- Widest range of materials: ceramic, wood, composites, brick, concrete, ...
- Widest range of sizes from less than 100 mg to 100 ton
- Suitable for industrial and laboratory use

Technical information

- Frequency range 20 Hz - 150 KHz
- Reference accuracy better than 0.005%
- Resolution up to 1/1.000.000 (1 ppm)
- Vibration detector
- Acoustic detector
- Supply 100 - 240 VAC / 50-60 Hz

Options

- Frequency analysis
- FFT calculation for detection of multiple vibrational modes
- Selection of zones of interest by waveband filtering
- Oscilloscope function for time domain analysis
- Graphic visualisation of frequency domain
- Waterfall 3D plot

Applications

- Abrasives and grinding
- Building materials
- Geology
- Ceramics
- Friction materials
- Composite and plastics
- Metals and alloys
- Cement and concrete
- Refractories
- Wood and timber
- ...

"The solution for shop floor Quality Control, NDT for E- and G-Modulus and in depth materials analysis for R&D."

GrindoSonic
THE IMPULSE EXCITATION TECHNIQUE



NDT Supply.com, Inc.
7952 Nieman Road
Lenexa, KS 66214-1560 USA

Phone: 913-685-0675, Fax: 913-685-1125
e-mail: sales@ndtsupply.com, www.ndtsupply.com

