



Inocart NDT – Inocart HF

Cart for powder gun

Instruction manual

DRT7161

B - 2023/10

NDT Supply.com, Inc.
7952 Nieman Road
Lenexa, KS 66214-1560 USA

Phone: 913-685-0675, Fax: 913-685-1125
e-mail: sales@ndtsupply.com, www.ndtsupply.com



All communication or reproduction of this document, in any form whatsoever and all use or communication of its contents are forbidden without express written authorisation from **Sames**.

The descriptions and characteristics mentioned in this document are subject to change without prior notice

© Sames 2020 - Translation of the original instruction manual

Services



Certification and referencing

Sames is certified as a training center by the DIRRECTE of the Auvergne Rhône Alpes region under the number 84 38 06768 38.

Our company provides, throughout the year, training courses allowing you to acquire the essential know-how for the implementation and maintenance of your equipment in order to guarantee its performance in the long term.

A catalog is available on request.

www.sames.com/france/en/services-training.html



Line audits

As part of a technical assistance program for our customers using **Sames** equipment, the line audits are intended to help you optimize and control your production tool.

Our network of experts is continuously trained and qualified to provide our customers with technical expertise on the liquid or powder installations in which our equipment is integrated. The global environment of the production lines is taken into account during this technical audit.

A brochure is available for download:

www.sames.com/france/en/services-service-contract.html



Maintenance program

An annual maintenance program (including or not the consumables to be replaced during each intervention) can be considered with the partnership of **Sames**. It is associated with a preventive maintenance plan established during a first audit visit which details the control points necessary to guarantee the performance of the installed equipment.

www.sames.com/france/en/services-service-contract.html



Hotline

www.sames.com/france/en/services-service-contract.html

Inocart NDT – Inocart HF

1. Health and safety instructions -----	6
1.1. Configuration of the certified equipment	6
1.2. Marking	6
1.3. Meaning of pictograms	8
1.4. Simplified analysis of potential ignition sources according to Standard EN 80079-36	9
1.5. Precautions for Use	9
1.6. Warnings	9
1.7. Important recommendations	12
1.7.1. Ventilation.....	12
1.7.2. O-ring seals	12
1.7.3. Ambient temperature	12
1.7.4. Sound level.....	12
1.8. Guarantee	13
2. Introduction -----	14
2.1. General overview	14
3. Characteristics -----	15
3.1. General characteristics	15
3.2. Air compressed quality	15
4. Operation -----	15
5. Start up-----	17
5.1. Specific tool	17
5.2. Installation	17
5.3. Use of Inocart NDT or HF equipment	18
5.3.1. Powder application.....	18
6. Maintenance -----	19
6.1. Maintenance summary table	19
6.2. Preventive maintenance plan – See PMP 7161	20
6.3. Cleaning	20
6.3.1. Procedure A: Cleaning the cart	20
6.3.2. Procedure B: Cleaning of the injection air check valve	21
6.3.3. Procedure C: Dump of tank	21
6.4. Replacement	22
6.4.1. Procedure D1: Replacement of filter.....	22
6.4.2. Procedure D2: Replacement of vibrator	23
7. Spare parts list -----	24
7.1. Equipment Inocart NDT	25
7.2. Equipment Inocart HF	26
7.2.1. Inocart NDT/HF cart, Europe and US versions	27
8. Revision index History -----	29
9. Appendices -----	30

9.1. Maintenance preventive plan 30
9.2. EU and UK declarations of conformity 31

1. Health and safety instructions

This manual contains links to the following operating instructions:

- [see DRT7132](#) for the **Inogun M/M +** spray gun.
- [see DRT7145](#) for the **Inobox** control module.
- [see DRT7169](#) for the **NDT Pressure tank**.
- [see DRT7170](#) for the **HF Pressure tank**.

1.1. Configuration of the certified equipment

All of these operating manuals define the configuration of the certified equipment.

1.2. Marking

The **Inocart NDT/HF** is classified as category 3 according to the ATEX 2014/34/EU and SI 2016 No. 1107 directives and is designed for use in zone 22.

The mode of protection applied is "safety by design".



ATEX / UKCA **Inocart NDT** configurations

Inocart NDT 6m Europe version - P/N 910030369 Inogun M 6m - P/N 910030034 NDT pressure tank - P/N 910030917 Vibrator - P/N 910030011	Inocart NDT 12m Europe version- P/N 910030369-12 Inogun M 12m - P/N 910030034-12 NDT pressure tank - P/N 910030917 Vibrator - P/N 910030011	Inocart NDT 6m US version - P/N 910030908 Inogun M 6m - P/N 910030034 NDT pressure tank - P/N 910031523 Vibrator - P/N 910030896	Inocart NDT 12m US version - P/N 910030908-12 Inogun M 12m - P/N 910030034-12 NDT pressure tank - P/N 910031523 Vibrator - P/N 910030896	Inocart NDT P/N	Inobox NF P/N 910030576
X				910030369	X
	X			910030369-12	X
		X		910030908	X
			X	910030908-12	X

ATEX / UKCA **Inocart HF** configurations

Inocart HF 6m Europe version - P/N 910030367 Inogun M 6m - P/N 910030034 HF Pressure tank - P/N 910031405 Vibrator - P/N 910030011	Inocart HF 12m Europe version - P/N 910030367-12 Inogun M 12m - P/N 910030034-12 HF Pressure tank - P/N 910031405 Vibrator - P/N 910030011	Inocart HF 6m US version - P/N 910031513 Inogun M 6m - P/N 910030034 HF Pressure tank - P/N 910031512 Vibrator - P/N 910030896	Inocart HF 12m US version - P/N 910031513-12 Inogun M 12m - P/N 910030034-12 HF Pressure tank - P/N 910031512 Vibrator - P/N 910030896	P/N Inocart HF	Inobox NF P/N 910030576
X				910030367	X
	X			910030367-12	X
		X		910031513	X
			X	910031513-12	X

1.3. Meaning of pictograms

				
Warning electricity	Warning Automatic start-up	Warning Hot surface	Warning Explosive material	General warning sign
				
Warning High pressure	Warning Crushing of hands	Warning for explosive atmospheres	Warning Flammable material	Warning Corrosive substance
				
Warning Toxic material	Warning Harmful products	No access for people with active implanted cardiac devices	Wear ear protection	Wear a face shield
				
Wear respiratory protection	Wear safety footwear	Wear protective clothing	Wear protective gloves	Wear head protection
				
Opaque eye protection must be worn	General mandatory action sign	Connect an earth terminal to the ground	Refer to Instruction manual	

1.4. Simplified analysis of potential ignition sources according to EN 80079-36

Risk of ignition		Measures applied to prevent the source of ignition from becoming effective
Potential source of ignition	Description / Main cause (What are the conditions causing the risk of ignition)	Description of the measure applied
Hot surface	Vibrator heating in vibrating table version	Maximum vibrator surface temperature of 100°C
Static electricity	Internal electrostatic discharge in powder hose	Antistatic hose
	Electrostatic discharge on the cart	Equipotentiality of the metal parts + earthing
	Electrostatic discharge on the pressure tank	Equipotentiality of the metal parts + earthing

1.5. Precautions for Use

This document contains information that all operators should be aware of and understand before using the carts **Inocart**. This information highlights situations that could result in serious damage and indicates the precautions that should be taken to avoid them.



Before any use of the Inobox control module, check that all operators:



- have previously be trained by the company **Sames**, or by their distributors registered by them for this purpose.
- have read and understood the user manual and all rules for installation and operation, as laid out below.



It is the responsibility of the operators' workshop manager to ensure these two points and it is also his responsibility to make sure that all operators have read and understood the user manuals for any peripheral electrical equipment present in the powdering area.

1.6. Warnings



It is imperative that anyone wearing a pacemaker does not use the equipment and does not enter the projection area. High voltage can cause the pacemaker to malfunction.



This equipment may be hazardous if it is not used, disassembled and reassembled in accordance with the rules indicated in this manual and in any applicable European Standard or national safety regulations.



This equipment is intended for spraying powder paint only.



Equipment performance is only guaranteed if original spare parts distributed by Sames are used.



To guarantee an optimal assembly, spare parts must be stored in a temperature close to their temperature of use. Should the opposite occur, a sufficient waiting time must be observed before the installation, so that all the elements are assembled in the same temperature.



Equipment should only be used in well-ventilated areas to reduce health, fire and explosion hazards. The effectiveness of the exhaust ventilation system should be checked daily. Within explosive atmospheres produced by the spraying process, only appropriate explosion-proof electrical equipment has to be used.

- 1 The operator must wear shoes according to standard EN ISO 20344 and the insulation resistance measured must not exceed 100 MΩ.
- 2 The protective clothes, including gloves, must conform to standard EN 1149-5 and the insulation resistance measured must not exceed 100 MΩ.
- 3 Using individual protection equipment will limit the risks of contact and/or inhalation of toxic product, gas, vapours, fog or dusts that can be produced while using the equipment. The user has to follow the coating product manufacturer's recommendations.
- 4 Contact or inhalation of the products used with this equipment may be dangerous for personnel (see: safety data sheets for the products used). The pressure coating material or compressed air must not be directed at people or animals.
- 5 All conductive structures such as floors, powder spray station walls, ceilings, barriers, barriers, parts to be painted, powder dispensing tank placed in or near the work area and the ground terminal of the electro-pneumatic control module must be electrically connected to the grounding system for protecting the power supply.
- 6 The floor on which the operator works must be dissipative (bare concrete floor or metal grating). Never cover the floor with an insulating covering. In potentially explosive locations, floor assemblies must be dissipative in accordance with EN 61340-4-1.
- 7 Switch off the power supply to the **Inobox** before connecting the **Inogun M** gun.
Before disconnecting the gun, cut off the power supply to the **Inobox** (otherwise a malfunction may occur).
- 8 Never point the gun at a person or animal.
- 9 Powder spraying must be carried out in front of a ventilated station provided for this purpose. The activation of the **Inobox** must be controlled by the operation of the ventilation system.
The correct operation of the drive must be checked once a week.
- 10 The ambient operating temperature must be between 0 and 40°C.
- 11 The electrostatic powder spraying equipment must be maintained regularly in accordance with the indications and instructions given by **Sames**. Repairs must be carried out in strict accordance with these instructions.

- 12 The electrostatic powder spraying equipment should only be operated if it is in perfect condition. Damaged equipment must be removed from service immediately and repaired.
- 13 Before cleaning the projectors or doing any other work in the spray area, the power supply to the high-voltage generator must be disconnected, protected against restarting and the HV circuit protected. (spray gun) discharged to ground.
Cleaning must be carried out in mechanically ventilated areas.
- 14 **In the explosive zone**, it is forbidden to use non-certified electrical or non-electrical equipment such as electrical extension cords, multi-sockets, switches, etc.
- 15 The cart as well as the tanks must obligatorily be placed and used outside the explosive zone.
- 16 It is imperative to connect the earth terminal of the cart to the earth terminal of the powder coating installation (or of the powder coating booth) in order to ensure the safety of the operators and the correct operation of the powder coating equipment.
- 17 Any filling of the tank with powder must be done in a ventilated area provided for this purpose and under no circumstances in the vicinity of the cart.
- 18 The tank must be earthed at the terminal provided for this purpose.
- 19 If the tank is used outside the cart, it is imperative that it is electrically connected to earth via its body.
- 20 The cart must under no circumstances be used to carry or transport loads other than the pressure tank.

A warning sign in a language understood by the operator, summarising the safety rules described above, must be prominently displayed in the vicinity of the powder spray station.

1.7. Important recommendations

1.7.1. Ventilation

Do not start the powder application with the **Inogun M** spray gun until the spray booth ventilation system is switched on. If the ventilation is switched off, toxic substances or dust may remain in the spray booth and cause a risk of fire, poisoning or irritation.

1.7.2. O-ring seals

Use the seals recommended in this manual.

1.7.3. Ambient temperature

The equipment is designed to normally operate at an ambient temperature comprised between 0°C and + 40°C (32 °F to 104 °F)

The storage temperature must never exceed +60°C.

1.7.4. Sound level

The sound pressure level generated by **Inocart NDT / HF** carts is equal to 70 dBA under the specified conditions of use.

Conditions of measurement:

The equipment was put into operation at maximum characteristics, the measurements were carried out at different positions at 1 m from the cart without powder in the Powder laboratory at the **Sames** site in Meylan, France.

Method of measurement:

The acoustic pressure level, continuous, equivalent, weighted (70 dBA) is given in LEQ value, measured for observation periods of at least 30 seconds.

1.8. Guarantee

Under the guarantee, which applies only to the buyer, **Sames** agrees to repair operating faults resulting from a design fault, materials or manufacture, under the conditions set out below.

The guarantee claim must define the exact nature of the fault concerned, in writing.

The **Sames** guarantee only covers equipment that has been serviced and cleaned according to standard procedures and our own instructions, that has been fitted with parts approved by **Sames** or that has not been modified by the customer.

More precisely, the guarantee does not cover damage resulting from:

- the customer's negligence or inattention,
- incorrect use,
- failure to follow procedures,
- use of a control system not designed by **Sames** or a **Sames** control system modified by a third party without written permission from an authorized **Sames** technical agent,
- accidents such as: collision with external objects, or similar events,
- flooding, earthquake, fire or similar events,
- use of seals not complying with **Sames** recommendations,
- pollution of air circuits by fluids or substances other than air.

The **Sames** carts type **Inocart NDT** and **Inocart HF** are covered by a warranty (refer to the general sales conditions for its application).

The guarantee does not apply to wearing parts such as electrode supports, deflectors, powder tube, seals, etc...

The guarantee will take effect from the date of the first start-up or of the provisional acceptance report.

Under no circumstances, either in the context of this guarantee or in other contexts, will **Sames** be held responsible for physical injury or intangible damage, damage to brand image and loss of production resulting directly from its products.

2. Introduction

2.1. General overview

The **Inocart** is a space-saving and easy-to-handle cart designed for manual powder application.

The **Inocart** cart is equipped with the **Inobox** control module at the ideal height and with a inclination that can be customized by the operator for a perfect reading of the information, as well as the **Inogun M** gun that is installed at the right height on either side of the cart.

Equipped with several air quick couplers, its use and maintenance are optimized compared to previous generations.

Available in two versions:

- **Inocart NDT**: Equipped with a **NDT pressure tank** with a capacity of 15 litres. It is used for very low flow rates (maximum 30 gr/min with dry penetrant powder).
- **Inocart HF**: Equipped with an **NDT pressure tank** with a capacity of 24 litres, it is used for high flow rates.



Inocart NDT / HF equipment	
1	Inobox NF control module
2	NDT or HF pressure tank
3	Pressure tank support
4	Vibrator
5	Inogun M spray gun

3. Characteristics

3.1. General characteristics

The structure of the cart makes it possible to place:

- In the **NDT version**: a pressure tank that can hold approximately 15 liters of fluidised powder (i.e. approximately 5 to 7 kg of powder depending on density).
- In **HF version**: a pressure tank that can contain about 24 liters of fluidised powder (i.e. about 10 to 12 kg of powder depending on density).

	Inocart NDT	Inocart HF
Dimensions of the cart (H x W x D)	1230 x 490 x 720 mm	1230 x 490 x 720 mm
Approximate weight (without powder)	40 kg	45 kg

3.2. Air compressed quality

Characteristics of compressed air supply according to the standard NF ISO 8573-1:

Maximum dew point at 6 bar (87 psi)	Class 4 i.e + 3°C (38°F)
Maximum particle-size of solid pollutants	Class 3 i.e 5 µm
Maximum oil concentration	Class 1 i.e 0,01 mg / m ³ *
Maximum concentration of solid pollutants	Class 3 i.e 5mg / m ³ *

***: Values are given for a temperature of 20 °C (68 °F) at an atmospheric pressure of 1 013 mbar**

The filter installed on the **Inocart NDT/HF** is used to guarantee the correct operation of the equipment, in case of accidental non-compliance with the network compressed air filtration recommendations.

Inocart ® equipment air supply pressure	7 bar +/- 1 bar (*)
--	---------------------



(*) A pressure higher than 8 bar can cause malfunctions.

Total equipment consumption:

NDT version	Injection from 0 to 100 and fluidisation at 50	85 l/min max
HF version	Injection at 80 and fluidisation at 43 on Inobox	85 l/min whatever the position of the shutter

4. Operation

The **NDT and HF carts** mainly consist of a cart, an **Inobox NF** module, an **NDT or HF pressure tank** depending on the version and an **Inogun M** gun.

The **Inogun M** gun allows to:

- spray powder paint on an earthed part.
- electrically charge the powder so that it adheres to the part to be powdered.

The electric charge of the powder is ensured by an electrode located at the end of the nozzle. This electrode is brought to high voltage by a high voltage unit integrated in the gun barrel. The high-voltage unit is even supplied with low-voltage current by the **Inobox NF** control module.

The powder paint is deposited in the NDT or HF pressure tank:

- The injection air (check valve Item **5**) is used to pressurize the **NDT or HF pressure tank**.
- The powder contained in the tank (Item **3**) is fluidized at the fluidizing cup by means of air (fitting on the fluidizing cup **6**) passing through the porous cone **7**).
- The electric vibrator (**4**) prevents powder accumulation in the porous cone.
- The air jet from the injector carries the powder towards the ejector tube.
- **In NDT version:** The shutter (**2**) which more or less closes the powder ejector tube must be set to "0" at start-up. The dry developer flow rate is adjusted using the injection air on the Inobox control module or directly on the gun using the + and - keys. If the flow rate is not sufficient when the injection parameter is at 100, it can be increased by opening the shutter (**2**) slightly using the lever (**1**) located on the cover.
- **In the HF version:** On the Inobox control module, the injection setpoint must be set to 80 and the fluidisation to 43. The powder flow rate is adjusted using the lever (**1**) on the cover. This pilots the shutter (**2**) which more or less closes the powder ejector tube. The adjustment can be refined by changing the injection air set point on the Inobox module or directly on the gun.



In no case should the maximum filling height of the tank exceed a threshold of 10 cm below the end of the ejector tube.

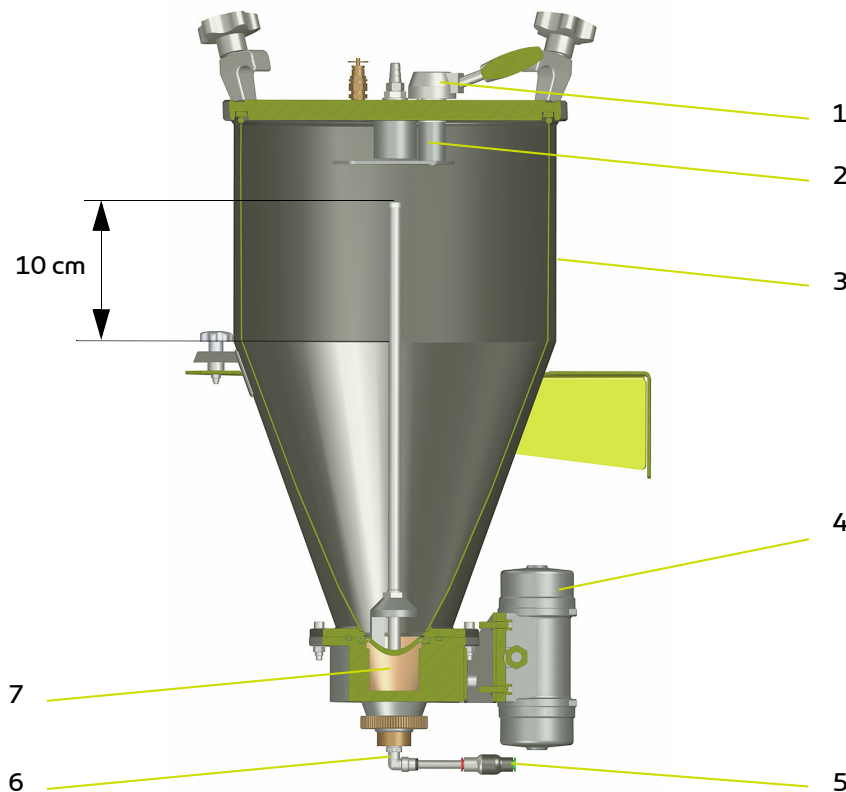

5. Start up

5.1. Specific tool

None.

5.2. Installation

The **Inocart NDT** or **HF** carts are delivered assembled.

- **Step 1:** Connect the ground cable of the cart to a conductive and earthed part of the spray booth; the ground potential must be identical to that of the part to be powdered.
- **Step 1:** Attach the tank support to the base of the cart using the 4 screws 8 x 25 provided.

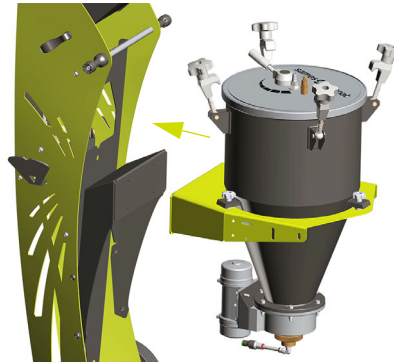

- **Step 2:** Connect the air supply and ground wire to the tank:
 Gun powder supply hose (1)
 Green/yellow wire: ground (2).
 Hose 4/6: dilution air for fluidization (3)
 Hose 6/8: injection air (4).



- **Step 3:** Connect the 5 m earthing cable to an electrically earthed part of the application booth.



- **Step 4:** Connect the Inobox's power supply plug.
- **Step 5:** Connect the electrode blowing hose on the **Inobox** module side and on the gun side.

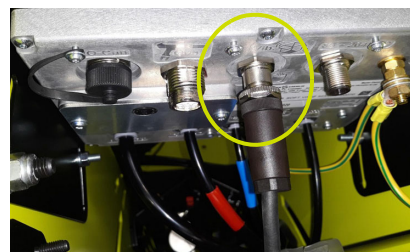

The cart is ready to start the powder application.

5.3. Use of Inocart NDT or HF equipment

5.3.1. Powder application

As the equipment has already been installed according to the safety rules ([see § 1 page 6](#)) and the instructions given ([see § 5.2 page 17](#)), follow the steps described below:

- **Step 1:** Connect the ground cable of the cart to a conductive and earthed part of the spray booth; the ground potential must be identical to that of the part to be powdered.
- **Step 2:** Electrically and pneumatically power the equipment.
- **Step 3:** Put powder in the pressure tank and close the lid with the clamps.



Tank under pressure in operation.

- **Step 4:** Switch on the **Inobox** control module ([see DRT7145](#)) (ON button on the front of the module. Configure the **Inobox NF** control module ([see DRT7145](#)), for pressure tank operation. The fluidizing outlet at the rear of the module must be plugged.
- **Step 5:** Choose the appropriate high-voltage feature or create a custom program.
- **Step 6:** Point the gun nozzle towards the booth and the part to be powdered and press the trigger.

5.3.1.1. In Non destructive Testing Powder (NDT) use

The **NDT pressure tank** is equipped with 2.7mm injector, 2.7mm ejector and 6mm inner diameter hose.

- Close the NDT tank shutter fully (position 0).
- Set the fluidization to setpoint 50. The dry developer flow rate can then be adjusted on the **Inobox** module or directly on the gun by varying the injection parameter (0 to 100). If the flow rate is not sufficient, the control shutter can be opened slightly.

5.3.1.2. In powder coating (HF) use

This equipment can be used for the application of difficult powders, very high flow rates can then be achieved. However, the acceptable use limit of a conventional electrostatic gun (charge capacity) is reached at 15kg/h of powder (250g/min).

The **HF pressure tank** is equipped with an ejector D: 1.7 mm, a 9/13 EVA hose and a suitable powder fitting ([see DRT7170](#)).

- Set the injection parameter (on the **Inobox** module or directly on the gun) to 80 and the fluidization to 43.
- Then adjust the powder flow rate by adjusting the position of the shutter on the pressure tank.

As an indication, with 6 m of 9mm hose and with a standard powder:

Shutter position	1	2	3	4	5
Powder flow rate (kg/h)	6	14	44	70	80

6. Maintenance

Note: This paragraph applies only to the maintenance of the Inocart cart.
 For specific maintenance of the gun ([see DRT7132](#)) and the Inobox control module ([see DRT7145](#)).



Disconnect the power supply to the control module before connecting the gun. Before disconnecting the gun, switch off, cut off the power supply to the control module (otherwise a malfunction may occur).

6.1. Maintenance summary table

The soiling and wear of the different elements of the **Inocart** carriage caused by the passage of the powder depends on the nature of the powder and the operating conditions.

Therefore, the periodicity of maintenance indicated in the procedures below is only indicative. The user will have to create his own maintenance range as he uses the **Sames** equipment.

Procedure	Detail	Duration	Frequency	
Cleaning				
A	Cleaning of the cart	2 min	8 Hours	
B	Cleaning of the injection air check valve	2 min	-	
C	Dump of tank	5 min	8 Hours or at each color change	
Replacement				
D	D1	Replacement of filter	10 min	-
	D2	Replacement of vibrator	30 min	-

6.2. Preventive maintenance plan – See PMP 7161

The objective of the proposed preventive maintenance plan is to define in an exhaustive way, the verification, replacement and cleaning actions of the installed **Sames** equipment.

In order to anticipate breakdowns and malfunctions that may be due to technical deviations of the installation, the preventive maintenance plan attached to the user manual lists the routine maintenance operations necessary for better comfort in the use of the production tool.

Depending on the skills, area of responsibility and accreditation of each person involved, the preventive maintenance plan can be divided into two distinct levels: level 1 and level 2:

- **Level 1:** first level maintenance is essentially composed of visual control and cleaning operations of some elements of the equipment. To limit this level, only the specific tools supplied with the equipment will be used. This first level of maintenance is generally taken care of by paint operators or installation managers.
- **Level 2:** second level maintenance completes the first level by more complex dismantling operations requiring electrical engineering tools. This second level is generally handled by the factory maintenance department.

6.3. Cleaning

6.3.1. Procedure A: Cleaning the cart

Before any intervention, refer to the health and safety instructions ([see § 1.6 page 9](#)).



Always wear safety glasses.



**When handling powder, wear gloves of a suitable resistant material
Work in a well ventilated area.**



**All cleaning operations should only be carried out using compressed air at a maximum pressure of 2.5 bar, a cloth or possibly a brush.
Never use water or solvents to clean the equipment.**

- Clean the complete **Inocart** cart with compressed air every 8 hours.

6.3.2. Procedure B: Cleaning of the injection air check valve

- Switch off the high-voltage supply,
- **Step 1:** Switch off the air supply
- **Step 2:** Disconnect the hose upstream of the valve by pressing the green ring, then downstream on the red ring.
- **Step 3:** Then clean the valve with compressed air. If necessary, clean the tank injector.

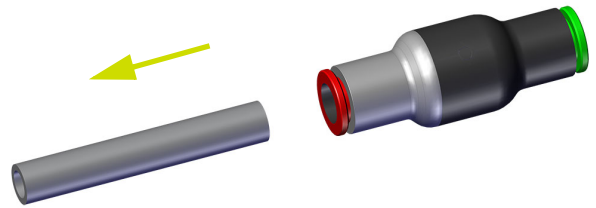

6.3.3. Procedure C: Dump of tank

6.3.3.1. Procedure 1

- **Step 1:** Disconnect the air supplies on the tank.
- **Step 2:** Remove the cover by unscrewing the clamps.
- **Step 3:** Disconnect the ground wire from the tank.
- **Step 4:** Unscrew the 3 knobs that secure the tank to the tank holder. Take out the tank, taking care not to shock the vibrator.
- **Step 5:** Empty the tank into the booth and clean the remaining powder with compressed air.

6.3.3.2. Procedure 2

- **Step 1:** Disconnect the injection air supply to the pressure tank.
- **Step 2:** Place a recovery box under the pressure tank.
- **Step 3:** Unscrew the threaded ring and pull the injector/ejector assembly upwards. The powder then falls into the tray. Clean the remaining powder with compressed air.

6.4. Replacement

The following maintenance operations are to be carried out in the workshop.

6.4.1. Procedure D1: Replacement of filter

- **Step 1:** Remove the rear panel from the cart.
- **Step 2:** Disconnect the air supplies.



- **Step 3:** Unscrew the brass plug (A) and remove the filter assembly.
- **Step 4: To reassemble, proceed in reverse order:**
Replace the complete filter assembly.
Attach the filter to the arm support with the brass plug, the washer is placed inside and the plug is placed outside.
Reconnect the air supplies.
Replace the rear panel.

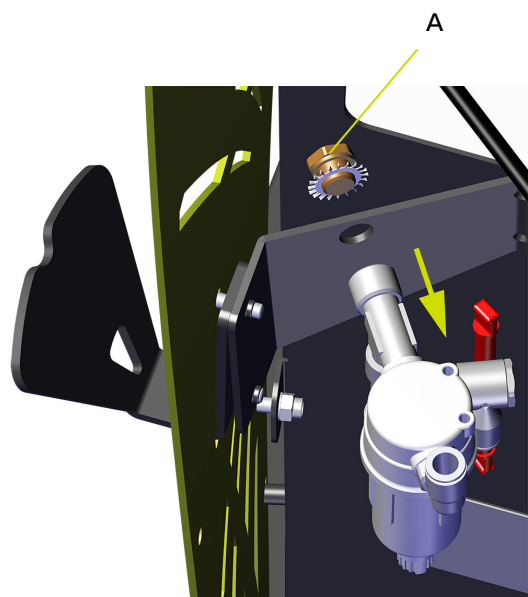

6.4.2. Procedure D2: Replacement of vibrator

Removal

- **Step 1:** Disconnect the vibrator cable on the **Inobox** side.
- **Step 2:** Disconnect the ground wire from the vibrator.

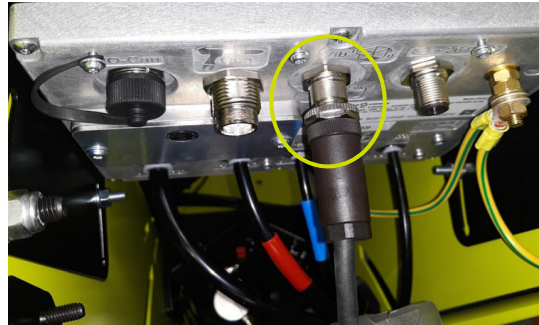

- **Step 3:** Unscrew the 4 vibrator fastening screws.

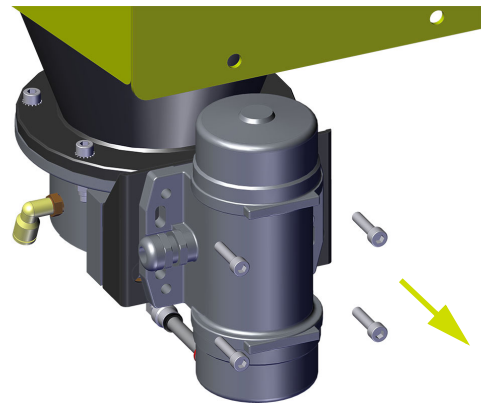

Reassembly

- **Step 4:** Apply a few drops of normal threadlocker (P/N H2CPAL046) on the 4 fixing screws
- **Step 5:** Place the vibrator on the cart, screw the screws crosswise and in approach, then tighten to a torque of 10 N.m.
- **Step 6:** Attach the ground cable lug by tightening the screw to a torque of 7 N.m.
- **Step 7:** Replace the vibrator panel on the **Inobox** side.

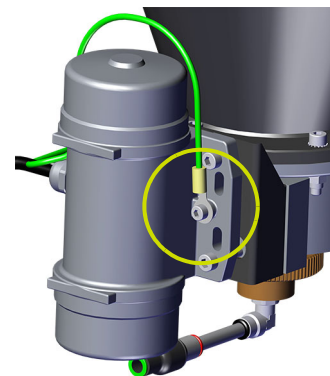
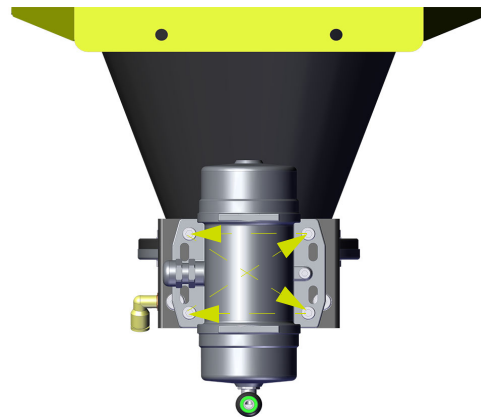

7. Spare parts list

The spare parts are classified in 2 different types:

- **1st emergency parts:**

The 1st emergency parts are strategic components which are not necessarily consumables but which in case of failure prohibit the operation of the equipment.

Depending on the production line's commitment and the production rates imposed, the first emergency parts are not necessarily kept available in the customer's stock.

Indeed, if an interruption of the production flow is possible, storage is not necessary.

On the other hand, if the stop is not possible, the 1st emergency parts will be kept in stock.

- **Wearing parts:**

Wearing parts are consumable components such as O-rings that undergo regular degradation over time during normal operation of the installation. It is therefore advisable to replace them according to a defined frequency and adapted to the operating time of the installation.

The wearing parts must therefore be kept in the customer's stock.



To guarantee an optimal assembly, spare parts must be stored in a temperature close to their temperature of use. Should the opposite occur, a sufficient waiting time must be observed before the installation, so that all the elements are assembled in the same temperature.

7.1. Equipment Inocart NDT

Europe version

Part Number	Description	Qty	Unit of sale	Maintenance level for spare parts (*)
910030369	Inocart NDT - 6m	1	1	-
910030369-12	Inocart NDT - 12m	1	1	-
910030917	NDT Pressure tank (see DRT7169)	1	1	-
	Inocart NDT/HF (see § 7.2.1 page 27)	1	-	-
910030041	Inobox EU power cable, length: 2.5 m	1	1	-
130002067#	Green POE hose Ø 6 mm antistatic	6 m	50 m	2
	Green POE hose Ø 6 mm antistatic	12 m	50 m	2
130000625-6	Polyurethane electrode air hose Ø 6mm black antistatic	1	1	2
130000625-12	Polyurethane electrode air hose Ø 6mm black antistatic	1	1	2
Not shown				
910031355	Inobox UK power cable, length: 2 m	1	1	-

US version

Part Number	Description	Qty	Unit of sale	Maintenance level for spare parts (*)
910030908	Inocart NDT US - 6m	1	1	-
910030908-12	Inocart NDT US - 12m	1	1	-
910031523	NDT Pressure tank - US (see DRT7169)	1	1	-
-	Inocart NDT/HF (see § 7.2.1 page 27)	1	-	-
910030398	Inobox US power cable, length: 2.5 m	1	1	-
130002067#	Green POE hose Ø 6 mm antistatic	6 m	50 m	2
	Green POE hose Ø 6 mm antistatic	12 m	50 m	2
130000625-6	Polyurethane electrode air hose Ø 6mm black antistatic	1	1	2
130000625-12	Polyurethane electrode air hose Ø 6mm black antistatic	1	1	2

(*)

Level 1: 1st emergency parts

Level 2: Wearing parts

7.2. Equipment Inocart HF

Europe version

Part Number	Description	Qty	Unit of sale	Maintenance level for spare parts (*)
910030367	Inocart HF - 6m	1	1	-
910030367-12	Inocart HF - 12m	1	1	-
910031405	HF Pressure tank (see DRT7170)	1	1	-
	Inocart NDT/HF (see § 7.2.1 page 27)	1	-	-
910030041	Inobox EU power cable, length: 2.5 m	1	1	-
U1FGBA104#	EAV 9/13 mm Hose	6 m	50 m	2
	EAV 9/13 mm Hose	12 m	50 m	2
130000625-6	Polyurethane electrode air hose Ø 6mm black antistatic	1	1	2
130000625-12	Polyurethane electrode air hose Ø 6mm black antistatic	1	1	2
Not shown				
910031355	Inobox UK power cable, length: 2 m	1	1	-

US version

Part Number	Description	Qty	Unit of sale	Maintenance level for spare parts (*)
910031513	Inocart HF US - 6m	1	1	-
910031513-12	Inocart HF US - 12m	1	1	-
910031512	HF Pressure tank - US (see DRT7170)	1	1	-
-	Inocart NDT/HF (see § 7.2.1 page 27)	1	-	-
910030398	Inobox US power cable, length: 2.5 m	1	1	-
U1FGBA104#	EAV 9/13 mm Hose	6 m	50 m	2
	EAV 9/13 mm Hose	12 m	50 m	2
130000625-6	Polyurethane electrode air hose Ø 6mm black antistatic	1	1	2
130000625-12	Polyurethane electrode air hose Ø 6mm black antistatic	1	1	2

(*)

Level 1: 1st emergency parts

Level 2: Wearing parts

7.2.1. Inocart NDT/HF cart, Europe and US versions



Item	Part Number	Description	Qty	Unit of sale	Maintenance level for spare parts (*)
	-	Inocart NDT/HF cart	1	-	-
1	910030576	Inobox HF control module (see DRT7145)	1	1	-
2	EU9000064	Conductive front swivel wheel	2	1	-
	250000422	Chc bombée M10 x 30 curved screw stainless	2	1	-
	EU9000837	Fan washer Dia.: 10	2	1	-
	X2BDZU010	Washer Z10 U galvanized steel	2	1	-
	X2BEHS010	Galvanized nylstop nut M 10 U	2	1	-
3	200000441	Rear wheel	2	1	-
	250000419	Chc M 8 / 16 curved screw stainless	2	1	-
	X2BDTU008	Steel zinc-plated Washer 8	2	1	-
4	910030034	Inogun M spray gun (with cable length: 6 m) (see DRT7132)	1	1	-
	910030034-12	Inogun M spray gun (with cable length: 12 m) (see DRT7132)	1	1	-
Not shown					
	160000148	5 micron air filter assembly	1	1	-
	130001492	PU hose D: 10 x 1,25 black antistatic (connection between filter and Inobox)	0,4 m	m	2
	130000625	Black Polyurethane hose D: 06x1 (Dilution air)	1,3 m	m	2
	130000624	PU hose D: 08 x 1,25 black antistatic (Injection air)	1,3 m	m	2

(*)

Level 1: 1st emergency parts

Level 2: Wearing parts

8. Revision index History

Created by:		Checked by: S Tadem		Approved by: S. Court	
Date	By:	Index	Purpose of the modification and location		
2020/09	S. Court	A	First issue		
2023/10	O. Aubin	B	UKCA Marking Change of identity and logo Update of the graphic charter		

9. Appendices

9.1. Maintenance preventive plan

9.2. EU and UK declarations of conformity



UE DECLARATION OF CONFORMITY

- (1) **The manufacturer herewith declares that the equipment is in conformity with the relevant Union harmonization legislation.**

(2) Equipment type	Chariot poudre / Powder cart		
	Inocart NDT, Inocart HF		
(3) Applicable Directives	2014/34/UE ATEX Directive	(4) Marking	 II 3 D Ex h IIIC T100°C Dc
		(5) Harmonised standards	EN 80079-36 : 2016 EN 80079-37 : 2016
		(6) Conformity assessment procedure	Module A Technical Documentation
	2006/42/CE Machinery Directive	(5) Harmonised standards	EN ISO 1200 : 2010
(7) This declaration of conformity is issued under the sole responsibility of the manufacturer.			

Director of the MEYLAN site - Executive Management (EM)

Richard WLODARCZYK

DocuSigned by:
Richard Wlodarczyk
9900D9C0034B4A2...

Established in Meylan, on 24-avr.-23 | 10:41 CEST

NDT Supply.com, Inc.

7952 Nieman Road
Lenexa, KS 66214-1560 USA

Phone: 913-685-0675, Fax: 913-685-1125
e-mail: sales@ndtsupply.com, www.ndtsupply.com





UE DECLARATION OF CONFORMITY

(1)	<p>Le Fabricant déclare que le matériel désigné ci-après est conforme à la législation d'harmonisation de l'Union applicable suivante/ Der Hersteller erklärt, dass das nachfolgend bezeichnete Material den folgenden anwendbaren Harmonisierungsrechtsvorschriften der Union entspricht / El fabricante declara que el equipo designado a continuación es conforme con la siguiente legislación de armonización de la UE aplicable / Il fabbricante dichiara che l'attrezzatura designata di seguito è conforme alla seguente legislazione di armonizzazione UE applicabile / O Fabricante declara que o equipamento designado abaixo está em conformidade com a seguinte legislação de harmonização aplicável da UE / Producent deklaruje, że urządzenie wskazane poniżej jest zgodne z następującymi obowiązującymi przepisami harmonizacyjnymi UE/ De fabrikant verklaart dat de hieronder beschreven apparatuur in overeenstemming is met de volgende toepasselijke EU-harmonisatiewetgeving/ Výrobce prohlašuje, že níže uvedené zařízení je ve shodě s těmito platnými harmonizačními právními předpisy EU/ Výrobce prohlašuje, že níže uvedené zařízení je ve shodě s těmito platnými harmonizačními právními předpisy EU/ Producenten erklærer, at det nedenfor angivne udstyr er i overensstemmelse med følgende gældende EU-harmoniseringslovgivning/ Valmistaja vakuuttaa, että jäljempänä mainitut laitteet ovat seuraavien sovellettävien EU:n yhdenmukaistamislainsäädäntöjen mukaisia./ Tootja kinnitab, et allpool nimetatud seadmed vastavad järgmistele kohaldatavatele ELi ühtlustamise õigusaktidele./ Ražotājs apliecina, ka turpmāk norādītās iekārtas atbilst šādiem piemērojamiem ES saskaņošanas tiesību aktiem./ Gamintojas pareiškia, kad foliau nurodyta įranga atitinka šiuos taikytinus ES derinamuosius teisės aktus/ Производителят декларира, че посоченото по-долу оборудване е в съответствие със следното приложимо законодателство на ЕС за хармонизация/ A gyártó kijelenti, hogy az alább megjelölt berendezés megfelel a következő alkalmazandó uniós harmonizációs jogszabályoknak / Producătorul declară că echipamentul desemnat mai jos este în conformitate cu următoarea legislație de armonizare a UE aplicabilă/ Ο κατασκευαστής δηλώνει ότι ο εξοπλισμός που αναφέρεται κατωτέρω συμμορφώνεται με την ακόλουθη ισχύουσα νομοθεσία ενωρίων της ΕΕ/ Προϊζνοδαč ovime izjavljuje da je oprema u skladu sa zakonskim zahtjevima Ujedinjene Kraljevine./ Výrobca vyhlasuje, že nižšie uvedené zariadenie je v súlade s týmito platnými harmonizačnými právnymi predpismi EÚ/ Произвојалец изјављује, да је сподјат наведена опрема складна з насљедњом велјавно усклајевално законодајо ЕУ/ Производител заявяет, что указанное ниже оборудование соответствует следующим применимым законодательным актам ЕС по гармонизации/ 製造者は、以下に指定された装置が、適用される以下のEU調和法に適合していることを宣言する。/ 製造商声明, 下面指定的设备符合以下适用的欧盟协调立法。</p>
(2)	Type d'équipement/ Art der Ausrüstung/ Tipo de equipo/ Tipo di attrezzatura/ Tipo de equipamento/ Rodzaj sprzętu/ Type uitrusting/ Typ zařízení/ Typ av anordning/ Type af anordning/ Laitteen tyyppi/ Seadme tüüp/ Iekārtas tips/ Įrangos tipas/ Вид оборудване/ A berendezés típusa/ Tipul de echipament/ Τύπος εξοπλισμού/ Vrsta opreme/ Typ zariadenia/ Vrsta naprave/ Тип оборудования/ 機器の種類/ 设备类型
(3)	Directives applicables/Anwendbare Richtlinien/Directivas aplicables/Direttive applicabili/Diretivas aplicáveis/Obowiązujące dyrektywy/Toepasselijke richtlijnen/Platné smernice/ Tillämpiga direktiv/ Gældende direktiver/ Sovellettavat direktiivit/ Kohaldatavad direktiivid/ Piemērojams direktīvas/ Taikomas direktīvos/ Приложими директиви/ Alkalmazandó irányelvek/ Directive aplicabile/ Ισχύουσες οδηγίες/ Primjenjive smjernice/ Uplatnitelne smernice/ Veljavne directive/ Применимые директивы/ 適用される指令/ 适用的指令
(4)	Marcaje/ Markierung/ Marcado/ Marcatura/ Marcação/ Znakovanie/ Markering/ Označení/ Märkning/ Märkning/ Merkintä/ Märgistus/ Marķējums/ Ženklinimas/ Маркировка/ Jelölés/ Marcare/ Ίζημανση/ Obilježava/ Označovanie / Označevanje/ Маркировка/ マーキング/ 标识
(5)	Normes harmonisées/Harmonisierte Normen / Normas armonizadas/ Norme armonizate/ Normas harmonizadas / Normy zharmonizowane / Geharmoniseerde normen / Harmonizované normy / Harmoniserade standarder / Harmoniserede standarder / Yhdenmukaistetut standardit / Harmoniseritud standardid / Saskaņotie standarti / Suderintie standarti / Хармонизирани стандарти / Harmonizált szabványok / Standarde armonizate/ Evarmonizēma protokola/ Harmonizirani standardi / Harmonizované normy / Usklajeni standardi / Гармонизированные стандарты / 整合規格 / 协调标准
(6)	Procédure d'évaluation de la conformité/Verfahren der Konformitätsbewertung/Procedimiento de evaluación de la conformidad/Procedura di valutazione della conformità/Procedimento de avaliação da conformidade/Procedura oceny zgodności/Conformiteitsbeoordelingsprocedure/Postup posuzování shody / Förfarande för bedömning av överensstämmelse/Procedure for overensstemmelsesvurdering / Vaatimustenmukaisuuden arviointimenettely / Vastavushindamismenetlus/Atbilstības novērtēšanas procedūra / Atitikties vertinimo procedūra / Процедура за оценка на съответствието / Megfelelőségértékelési eljárás / Procedura de evaluare a conformității/ Διαδικασία αξιολόγησης της συμμόρφωσης / Postupak ocjene uskladnosti / Postup posuzovania shody / Postopek ugotavljanja skladnosti / Процедура оценки соответствия / 適合性評價手順 / 符合性評估程序
(7)	Cette déclaration de conformité est délivrée sous la seule responsabilité du fabricant. / Diese Konformitätserklärung wird unter der alleinigen Verantwortung des Herstellers ausgestellt./ Esta declaración de conformidad se emite bajo la única responsabilidad del fabricante./ Questa dichiarazione di conformità è rilasciata sotto la sola responsabilità del produttore./ Esta declaração de conformidade é emitida sob a exclusiva responsabilidade do fabricante./ Niniejsza deklaracja zgodności została wydana na wyłączną odpowiedzialność producenta./ Deze verklaring van overeenstemming wordt afgegeven onder de uitsluitende verantwoordelijkheid van de fabrikant./ Toto prohlášení o shodě je vydáno na výhradní odpovědnost výrobce./ Denna försäkran om överensstämmelse utfärdas på tillverkarens eget ansvar. / Denne overensstemmelseserklæring er udstedt på producentens eget ansvar./ Tämä vaatimustenmukaisuusvakuutus annetaan valmistajan yksinomaisella vastuulla./ Käesolev vastavusdeklaratsioon on välja antud tootja ainuvastutusel./ Šī atbilstības deklarācija ir izdota uz ražotāja atbildību./ Už šią atitikties deklaraciją atsako tik gamintojas./ Настоящата декларация за съответствие се издава на пълната отговорност на производителя./ Ezt a megfelelőségi nyilatkozatot a gyártó kizárólagos felelősége mellett adjuk ki./ Prezenta declarație de conformitate este emisă pe răspunderea exclusivă a producătorului./ Η παρούσα δήλωση συμμόρφωσης εκδίδεται με αποκλειστική ευθύνη του κατασκευαστή./ Ova izjava o skladnosti izdaje se isključivo pod odgovornošću proizvođača./ Toto vyhlásenie o zhode sa vydáva na výhradnú zodpovednosť výrobcu./ Za to izjavo o skladnosti je odgovoren izključno proizvajalec./ Din izdelkarazjoni ta' konformità għandha tinfareġ taht ir-responsabbiltà unika tal-manifattur./ Данная декларация соответствия выдана под исключительную ответственность производителя./ この適合宣言は、製造者の単独責任のもとで発行されています。/ 本符合性声明由制造商全权负责发布。

NDT Supply.com, Inc.
7952 Nieman Road
Lenexa, KS 66214-1560 USA

Phone: 913-685-0675, Fax: 913-685-1125
e-mail: sales@ndtsupply.com, www.ndtsupply.com





UK DECLARATION OF CONFORMITY

(1) **The manufacturer herewith declares that the equipment is in conformity with the relevant Union harmonization legislation.**

(2) Equipment type	Chariot poudre / Powder cart		
	Inocart NDT, Inocart HF		
(3) Applicable Directives	2016 No. 1107	(4) Marking	 II 3 D Ex h IIIC T100°C Dc
		(5) Designated standards	EN 80079-36 : 2016 EN 80079-37 : 2016
		(6) Conformity assessment procedure	Module A Technical Documentation
	2008 No. 1597	(5) Designated standards	EN ISO 1200 : 2010
(7) This declaration of conformity is issued under the sole responsibility of the manufacturer.			

Director of the MEYLAN site - Executive Management (EM)

Richard WLODARCZYK

DocuSigned by:
Richard Wlodarczyk
9900D9C0034B4A2...

Established in Meylan, on 24-avr.-23 | 10:41 CEST

NDT Supply.com, Inc.

7952 Nieman Road
Lenexa, KS 66214-1560 USA

Phone: 913-685-0675, Fax: 913-685-1125
e-mail: sales@ndtsupply.com, www.ndtsupply.com





UK DECLARATION OF CONFORMITY

(1)	<p>Le Fabricant déclare que le matériel désigné ci-après est conforme à la législation d'harmonisation de l'Union applicable suivante/ Der Hersteller erklärt, dass das nachfolgend bezeichnete Material den folgenden anwendbaren Harmonisierungsrechtsvorschriften der Union entspricht / El fabricante declara que el equipo designado a continuación es conforme con la siguiente legislación de armonización de la UE aplicable / Il fabbricante dichiara che l'attrezzatura designata di seguito è conforme alla seguente legislazione di armonizzazione UE applicabile / O Fabricante declara que o equipamento designado abaixo está em conformidade com a seguinte legislação de harmonização aplicável da UE / Producent deklaruje, że urządzenie wskazane poniżej jest zgodne z następującymi obowiązującymi przepisami harmonizacyjnymi UE/ De fabrikant verklaart dat de hieronder beschreven apparatuur in overeenstemming is met de volgende toepasselijke EU-harmonisatiewetgeving/ Výrobce prohlašuje, že níže uvedené zařízení je ve shodě s těmito platnými harmonizačními právními předpisy EU/ Výrobce prohlašuje, že níže uvedené zařízení je ve shodě s těmito platnými harmonizačními právními předpisy EU/ Producenten erklærer, at det nedenfor angivne udstyr er i overensstemmelse med følgende gældende EU-harmoniseringslovgivning/ Valmistaja vakuuttaa, että jäljempänä mainitut laitteet ovat seuraavien sovellettavien EU:n yhdenmukaistamislainsäädäntöjen mukaisia./ Tootja kinnitab, et allpool nimetatud seadmed vastavad järgmistele kohaldatavatele ELi ühtlustamise õigusaktidele./ Ražotājs apliecina, ka turpmāk norādītās iekārtas atbilst šādiem piemērojamiem ES saskaņošanas tiesību aktiem./ Gamintojas pareiškia, kad toliau nurodyta įranga atitinka šiuos taikytinus ES derinamuosius teisės aktus/ Производителят декларира, че посоченото по-долу оборудване е в съответствие със следното приложимо законодателство на ЕС за хармонизация/ A gyártó kijelenti, hogy az alább megjelölt berendezés megfelel a következő alkalmazandó uniós harmonizációs jogszabályoknak / Producătorul declară că echipamentul desemnat mai jos este în conformitate cu următoarea legislație de armonizare a UE aplicabilă/ Ο κατασκευαστής δηλώνει ότι ο εξοπλισμός που αναφέρεται κατωτέρω συμμορφώνεται με την ακόλουθη ισχύουσα νομοθεσία ενωμοσύνης της ΕΕ/ Προϊζοδαč ovime izjavljuje da je oprema u skladu sa zakonskim zahtjevima Ujedinjene Kraljevine./ Výrobca vyhlasuje, že nižšie uvedené zariadenie je v súlade s týmito platnými harmonizačnými právnymi predpismi EÚ/ Произвојалец изјављује, да је спод ај наведена опрема складна з наследњо велјавно усклајевално законодајо EU/ Производител заявяет, что указанное ниже оборудование соответствует следующим применимым законодательным актам ЕС по гармонизации/ 製造者は、以下に指定された装置が、適用される以下のEU調和法に適合していることを宣言する。/ 製造商声明, 下面指定的设备符合以下适用的欧盟协调立法。</p>
(2)	<p>Type d'équipement/ Art der Ausrüstung/ Tipo de equipo/ Tipo di attrezzatura/ Tipo de equipamento/ Rodzaj sprzętu/ Type uitrusting/ Typ zařízení/ Typ av anordning/ Type af anordning/ Laitteen tyyppi/ Seadme tüüp/ Iekārtas tips/ Įrangos tipas/ Вид оборудване/ A berendezés típusa/ Tipul de echipament/ Τύπος εξοπλισμού/ Vrsta opreme/ Typ zariadenia/ Vrsta naprave/ Тип оборудования/ 機器の種類/ 设备类型</p>
(3)	<p>Directives applicables/Anwendbare Richtlinien/Directivas aplicables/Direttive applicabili/Directivas aplicáveis/Obowiązujące dyrektywy/Toepasselijke richtlijnen/Platné smernice/Tillämpliga direktiv/Gældende direktiver/Sovellettavat direktiivit/Kohaldatavad direktiivid/Piemērojams direktīvas/Taikomos direktyvos/Приложими директиви/Alkalmazandó irányelvek/Directive aplicabile/Ισχύουσες οδηγίες/Primjenjive smjernice/Uplatnitelne smernice/Veljavne directive/Применимые директивы/適用される指令/适用的指令</p>
(4)	<p>Marquage/Markierung/Marcação/Marcatura/Marcação/Znakowanie/Marketing/Označení/Märkning/Mærkning/Merkintä/Märkistus/Marķējums/Ženkinimas/Маркировка/Jelölés/Marcare/Ἱζηγανση/Obilježava/Označovanie /Označevanje/Маркировка/マーキング/ 标识</p>
(5)	<p>Normes désignées/Bezeichnete Normen /Normas designadas /Norme designate /Normas designadas /Normy wyznaczone / Aangewezen normen/Určené normy /Utpkede standarder /Udpegede standarder /Nimetyl standardit /Māāratud standardiā /Izraudzītie standarti /Paskirtieji standarti /Определени стандарти /Kijelölt szabványok /Standarde desemnate /Καθορισμένα πρότυπα /Određeni standardi /Určené normy / Določeni standardi /Назначенные стандарты /指定された規格/ 指定的标准</p>
(6)	<p>Procédure d'évaluation de la conformité/Verfahren der Konformitätsbewertung/Procedimiento de evaluación de la conformidad/Procedura di valutazione della conformità/Procedimento de avaliação da conformidade/Procedura oceny zgodności/Conformiteitsbeoordelingsprocedure/Postup posuzování shody / Förtärande för bedömning av överensstämmelse/Procedure for överensstemmelsesvurdering /Vaatimustenmukaisuuden arviointimenettely / Vastavushindamismenetlus/Atbilstības novērtēšanas procedūra /Atitikties vertinimo procedūra /Процедура за оценка на съответствието /Megfelelőségértékelési eljárás / Procedura de evaluare a conformității/Διαδικασία αξιολόγησης της συμμόρφωσης /Postupak ocjene usklađenosti /Postup posuzovania zhody /Postopek ugotavljanja skladnosti /Процедура оценки соответствия / 適合性評價手順/ 適合性評估程序</p>
(7)	<p>Cette déclaration de conformité est délivrée sous la seule responsabilité du fabricant. / Diese Konformitätserklärung wird unter der alleinigen Verantwortung des Herstellers ausgestellt./ Esta declaración de conformidad se emite bajo la única responsabilidad del fabricante./ Questa dichiarazione di conformità è rilasciata sotto la sola responsabilità del produttore./ Esta declaração de conformidade é emitida sob a exclusiva responsabilidade do fabricante./ Niniejsza deklaracja zgodności została wydana na wyłączone odpowiedzialności producenta./ Deze verklaring van overeenstemming wordt afgegeven onder de uitsluitende verantwoordelijkheid van de fabrikant./ Toto prohlášení o shodě je vydáno na výhradní odpovědnost výrobce./ Denna försäkrän om överensstämmelse utfärdas på tillverkarens eget ansvar. / Denne overensstemmelseserklæring er udstedt på producentens eget ansvar./ Tämä vaatimustenmukaisuusvakuutus annetaan valmistajan yksinomisella vastuulla./ Käesolev vastavusdeklaratsioon on välja antud tootja ainuvastutusel./ Šī atbilstības deklarācija ir izdota uz ražotāja atbildību./ Už šią atitikties deklaraciją atsako tik gamintojas./ Настоящата декларация за съответствие се издава на пълната отговорност на производителя./ Ezt a megfeleléségi nyilatkozatot a gyártó kizárólagos felelősége mellett adjuk ki./ Prezenta declarație de conformitate este emisă pe răspunderea exclusivă a producătorului./ Η παρούσα δήλωση συμμόρφωσης εκδίδεται με αποκλειστική ευθύνη του κατασκευαστή./ Ova izjava o skladnosti izdaje se isključivo pod odgovornošću proizvođača./ Toto vyhlásenie o zhode sa vydáva na výhradnú zodpovednosť výrobcu./ Za to izjavo o skladnosti je odgovoren izključno proizvajalec./ Din iddikjarazzjoni ta' konformità għandha tinhaqgħ taht ir-responsabbiltà unika tal-manifattur./ Данная декларация соответствия выдана под исключительную ответственность производителя./ この適合宣言は、製造者の単独責任のもとで発行されています。/本符合性声明由制造商全权负责发布。</p>

NDT Supply.com, Inc.

7952 Nieman Road
Lenexa, KS 66214-1560 USA

Phone: 913-685-0675, Fax: 913-685-1125

e-mail: sales@ndtsupply.com, www.ndtsupply.com



For almost a century, **Sames** has provided services and equipment for the application of liquid and powder paints, adhesives and sealants to bond, protect and beautify all types of surfaces.

We design, produce and market complete solutions - manual guns, automatic and robotic applicators, pumps and dosing machines...

We offer solutions at the cutting edge of technological innovation, serving industrial efficiency for the most challenging customers, and environmentally friendly.

Sames bonds, protects and beautifies all materials.

More than a supplier, **Sames** is the partner of your performance.

We *Simply Apply* the *Most Efficient Solutions*.

Enjoy being the best *together*



NDT Supply.com, Inc.

7952 Nieman Road
Lenexa, KS 66214-1560 USA

Phone: 913-685-0675, Fax: 913-685-1125
e-mail: sales@ndtsupply.com, www.ndtsupply.com

