

UDS2-77 AREMA

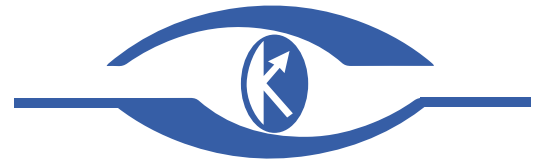

OKOndt GROUP



Ultrasonic Single Rail Flaw Detector

Complies with: AREMA requirements

Main Features of the flaw detector

- Weighs just 17 kg/37.4 lbs (for UDS2-77 AREMA SL) and 23 kg/50.6 lbs (for UDS2-77 AREMA RSU) due to use of light and shock-resistant plastic.
 - Flaw detector parking mode.
- Module structure: a frame on rollers, a central electronic unit, multiplexer units, storage battery, tank, couplant supply system, probe units, and encoder.
 - All modules are easy to assemble and disassemble; they are safely attached to the flaw detector frame.
 - Adjustable probe position to optimize signals.
 - Centering probe units along the rail axis with adaptive rollers.
 - The probe unit suspension system ensures stable acoustic contact in case of lateral inclination of the trolley at up to $\pm 15^\circ$ (for UDS2-77 AREMA (SL)).

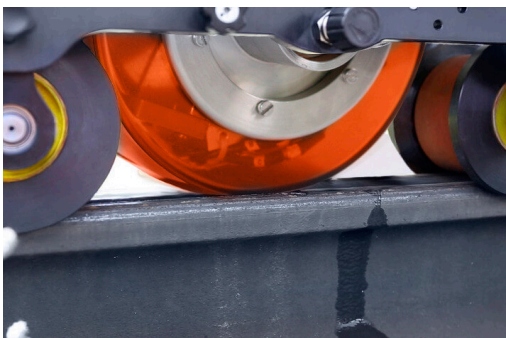

UDS2 - 77 AREMA Ultrasonic Single Rail Flaw Detector

Main technical specifications

The UDS2 - 77 ultrasonic flaw detector is intended for inspection of rails and switches, as well as for quick verification flaws detected by high speed test vehicles results. The flaw detector ensures flaw detection in the entire rail cross section, excluding rail base blades.



- Rail inspection complies with AREMA requirements.
- Number of inspection channels (probes) - 11 psc.
- Probe type and frequency:
0°/4 MHz, ±70°, ±40/45°, ±50°SL/2 MHz.
Scanning pitch 1mm at a speed of 4 km/h (2.5m/hr).
- Display modes: A-Scan, B-Scan, A-Scan+B-Scan.
- Continuous test result recorded in a database format linked to path and GPS coordinates.
Test result reviewing mode on the screen of the flaw detector.
- Flaw detector weight without couplant: no more than 17 kg (for UDS2-77 AREMA (SL) and 23 kg (for UDS2-77 AREMA (RSU))
Couplant tank volume: 5 l (1.3 gal).
- Couplant consumption: up to 1.5 l/km (0.4 gal), at a speed of 4 km/h (2.5 m/hr).
-

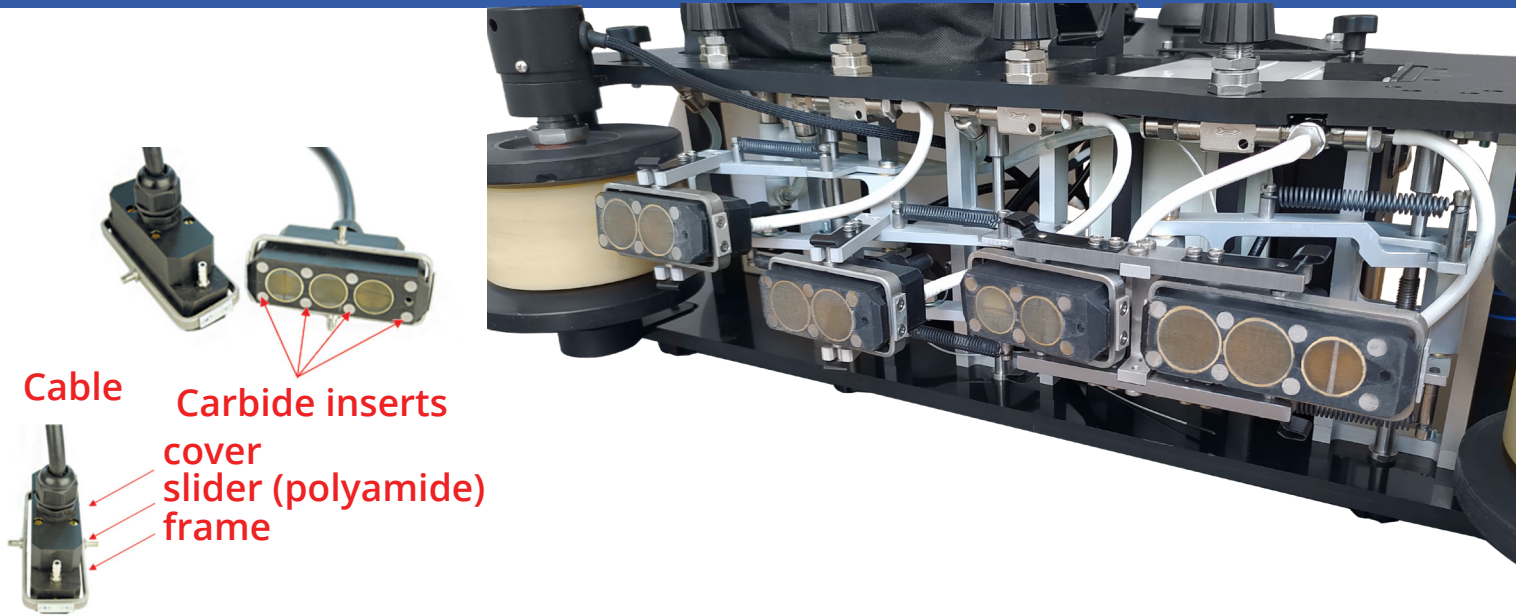

UDS2-77 AREMA (RSU) WHEEL PROBE

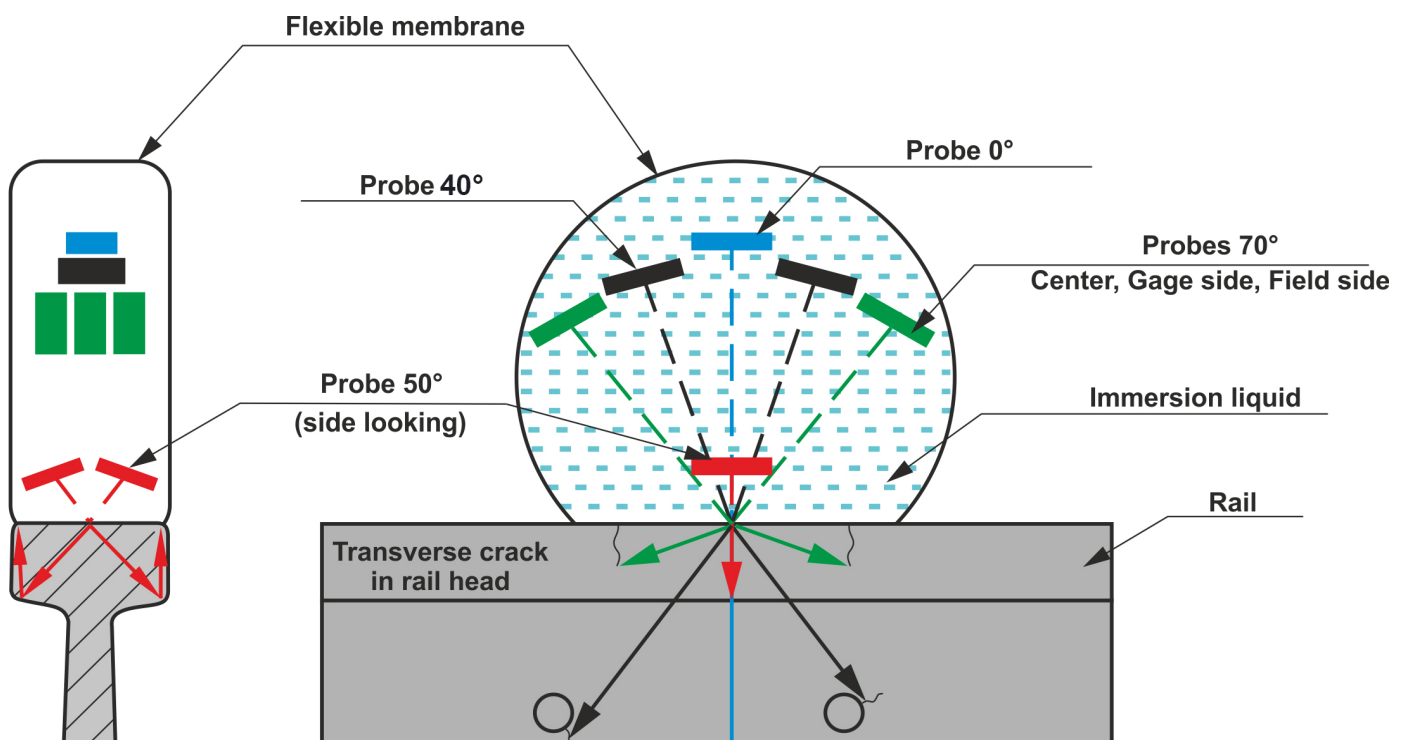

Specifications: UDS2-77 AREMA

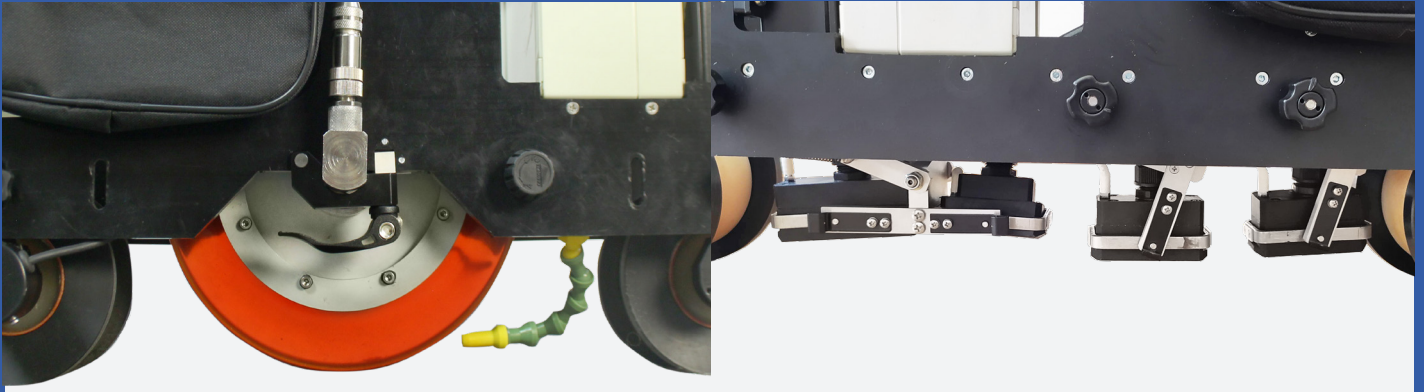

UDS2-77 AREMA (RSU)	UDS2-77 AREMA (SL)
Provides testing of rails in accordance with AREMA requirements	Provides testing of rails in accordance with AREMA requirements
Immersion probe unit design - wheel (RSU)	Sliding probe unit design (4 sliding blocks)
Number of ultrasonic probes - 11	Number of ultrasonic probes 11
0°-4 MHz	0°-4 MHz
70°-2 MHz (Head Central Forward)	70°-2 MHz (Head Central Forward)
70°-2 MHz (Head Central Backward)	70°-2 MHz (Head Central Backward)
70°-2 MHz (Head Gauge Face Forward)	70°-2 MHz (Head Gauge Face Forward)
70°-2 MHz (Head Gauge Face Backward)	70°-2 MHz (Head Gauge Face Backward)
70°-2 MHz (Head Field Face Forward)	70°-2 MHz (Head Field Face Forward)
70°-2 MHz (Head Field Face Backward)	70°-2 MHz (Head Field Face Backward)
2x40°- 2 MHz (Web, Foot Forward / Backward)	2x45°- 2 MHz (Web, Foot Forward / Backward)
2x50°- 2 MHz (Head Side Looking)	2x50°- 2 MHz (Head Side Looking)
Specifics of Application/Tester Comparison	
Limited to soft tire bumps	Limited to rail level differences of more than 15 mm (0.6") at rail junctions
Requires a strictly vertical position of trolley during rail testing	Trolley tilt of +/- 15° is acceptable during rail testing
Comparison of Costs, Repair and Maintenance	
The cost of repair/replacement of the probe unit (RSU) is higher	The cost of repair/replacement of sliding probe units is lower
The cost of soft tire replacement is smaller	The cost of sliding probe units replacement is higher
The process of soft tire replacement is more difficult	The process of sliding probes replacement is easier
Comparison of Flaw Detectors Costs	
Higher Cost	Lower Cost
Net weight (without liquid)	
Weight 23 kg (50.7 lbs.)	Weight 17 kg (37.5 lbs.)

Interface and main modes of the flaw detector software

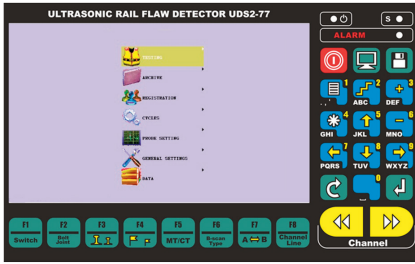

General flaw detector interface



Display mode: A-Scan for one channel

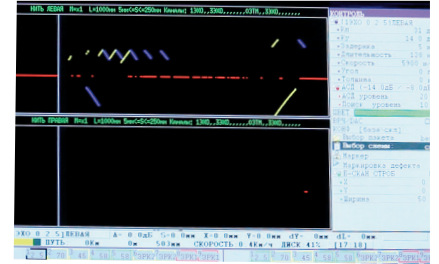

Display mode: A-Scan + B-Scan for one channel

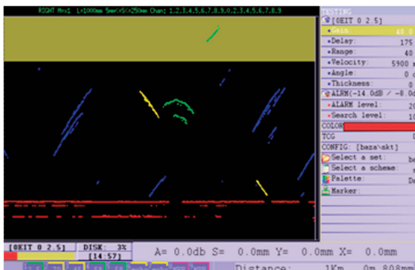

Display mode: B-Scan for one channel

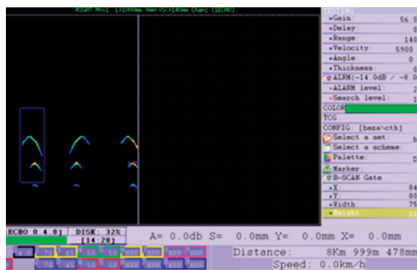

Display mode: B-Scan for one channel

Software for test result analysis and evaluation

The "Rail Inspector" program is intended for display, analysis and evaluation of test results on PC. The program includes all the necessary tools to process data.

The major advantages of the program are:

- Conveniently works with the database of inspected sections (stages);
- Selection of the layout of inspection channels, selection of an inspected rail, inspected rail segment, testing method;
- Measuring the notional size of defects in B-Scan mode;
- Viewing A-Scan based on the data recorded in B-Scan;
- Viewing a defectogram (B-Scan) in scroll mode or in mode of fast switch to the given coordinate;
- Path marking mode to mark suspicious segments of rail track while viewing test results;
- Sorting out test results by sensitivity level from -6 to +6 dB above or below the measuring gate level;
- Mode of viewing and producing reports on the inspected segment;
- Mode of viewing reports on confirmatory testing.

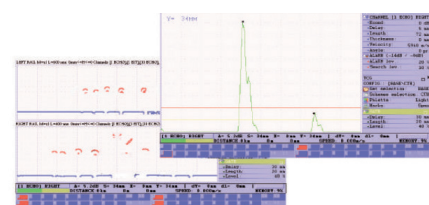
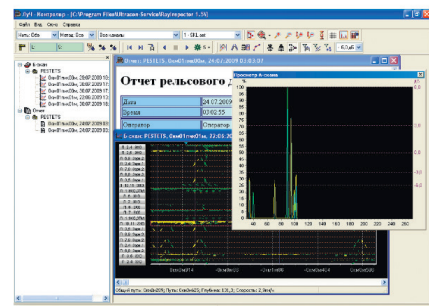

Position marks	
Instrument labels	User labels
Rail	Description
31km 105m 890mm	This rail section should be retested
31km 105m 604mm	
31km 105m 287mm	



OKO_{ndt} GROUP



NDT Supply.com, Inc.

7952 Nieman Road
Lenexa, KS 66214-1560 USA

Phone: 913-685-0675, Fax: 913-685-1125
e-mail: sales@ndtsupply.com, www.ndtsupply.com

