

AXIS Scanner

ULTIMATE POWER AND PRECISION IN SCANNING

Introducing the new **AXIS Scanner – High power and versatile design!**

The new Axis Scanner from ScanTech Instruments, Inc. is designed upon our Wheel Pack™ (WP) platform, which allows outstanding versatility as well as the highest power density on the market for small robotic drive units. Weighing in at 10lbs (4.54Kg) including the standard probe assembly, the scanner provides a pulling force over 5 times its weight.

The Axis scanner is ideal for obtaining Ultrasonic B-Scans (gated or Amplitude) axially on small radius vessels and piping. Its unique design allows the scanner to self-adjust to outer and inner radii for maximum contact of the magnetic wheels, increasing adhesion on vertical or inverted surfaces and maximizing traction. To overcome the powerful magnetic force of the wheels, removal of the scanner is greatly aided using the ergonomic integrated handles, which lever against two fulcrum blocks when the handles are pulled inward toward the center of the scanner.

A contributing factor to the compact design is the reduction of complexity resulting from simple three wheel contact, two of which are the powerful WP drive modules along with an undriven third magnetic wheel which having our integrated proprietary magnetic based encoder, offering additional adhesion power and accurate positional information free from wheel slippage effects of driven wheels when steering.

The WP modules offer the same advantages as our other ScanTech engineered drive train platforms, which have proven to be substantially "bullet proof", multiplying power from the highest power density electric motors on the market. The WP platform benefits as well from ScanTech's proprietary "STC" control system, which offers control for all of our current platforms from an intelligent 4 wire bus cable system, which offers lightweight and simple universal cabling with high expandability for our multi-axis robotic systems.

For ultrasonic applications the Axis leverages our proprietary "ACR" couplant flow probe module, as well as one of our "CCP" (Constant Contact Pressure) probe mechanisms. The ACR routing allows bubble free water column delay when using single element techniques as well as dual element, both available on all our ultrasonic scanners for needed flexibility. The ACR and CCP designs target our continual concentration on obtaining the highest possible UT data quality, equally important to the ease of use and durability we prioritize as well.

To keep our customers working in the field we offer the same attentive, friendly service we have provided for 27 years!



AXIS Scanner Key Features:

- **High Power Density:** Lightweight at 10lbs, yet offers a pulling force over 5 times its weight.
- **Versatile Design:** Ideal for ultrasonic B-Scans on small radius vessels and piping; self-adjusts for maximum surface contact.
- **Easy Removal:** Ergonomic handles with fulcrum blocks make detaching the scanner simple.
- **Accurate Positioning:** Integrated magnetic encoder ensures precise positioning without wheel slippage.
- **Reliable Drive System:** Features powerful WP drive modules and ScanTech's proprietary "STC" control system.
- **Superior Data Quality:** Utilizes "ACR" couplant flow and "CCP" probe mechanisms for high-quality ultrasonic testing.

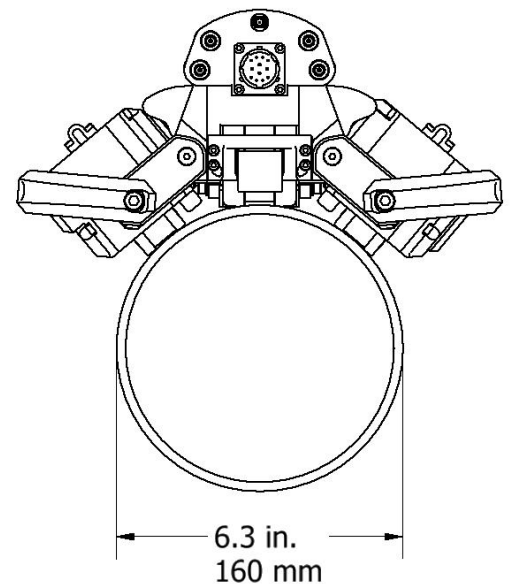
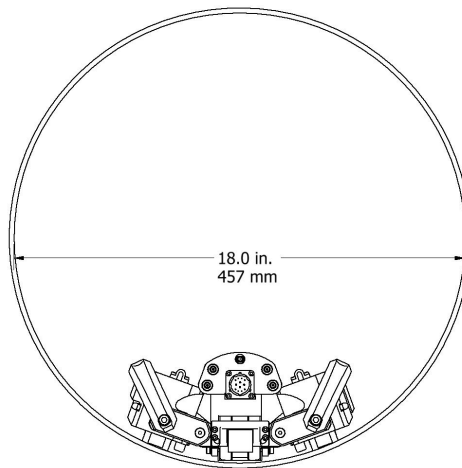
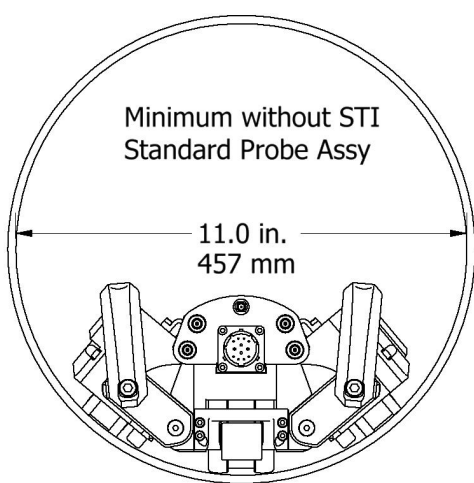
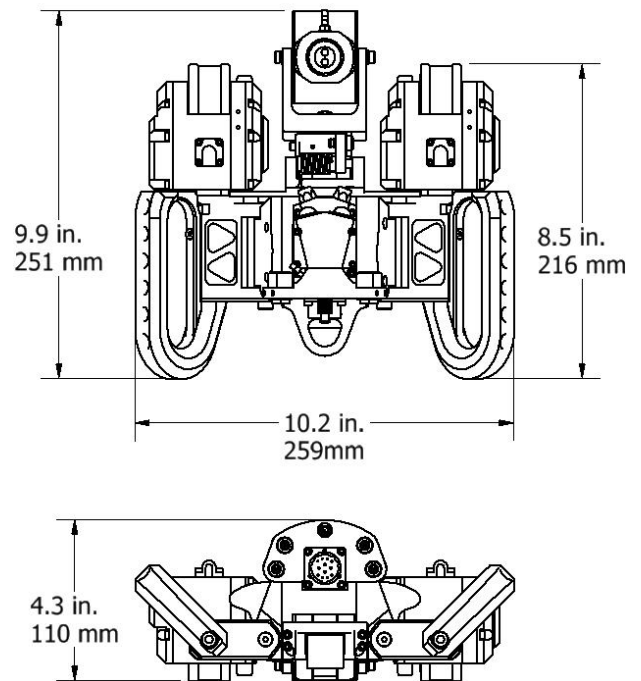

Specifications

Steering:

Joystick or Touchscreen

Speed:

6 in/sec
150 mm/sec

Tractive Pull Force:

>25 lbf
>110 N

Scanner Weight:

10 lb (with standard probe assy)
4.54 kg (with standard probe assy)

Magnetic Force:

>200 lbf (all wheels)
>900 lbf (all wheels)



SCANTECH

NDT Supply.com, Inc.

7952 Nieman Road
Lenexa, KS 66214-1560 USA

Phone: 913-685-0675, Fax: 913-685-1125
e-mail: sales@ndtsupply.com, www.ndtsupply.com

