

CIS SYSTEM COMPONENTS

UV AND WHITE LIGHT VIDEO INSPECTION

REVISIONS				
REV.	DESCRIPTION	BY	DATE	ECR/ECN#
A	UPDATED ANNOTATIONS	WJH	02/21/2013	
B	UPDATED MODEL TO LATEST REVISION	RBW	8/20/2013	
C	CHANGED TO 17" LCD HD MONITOR, LED LIGHT SOURCES	WJH	8/1/2023	

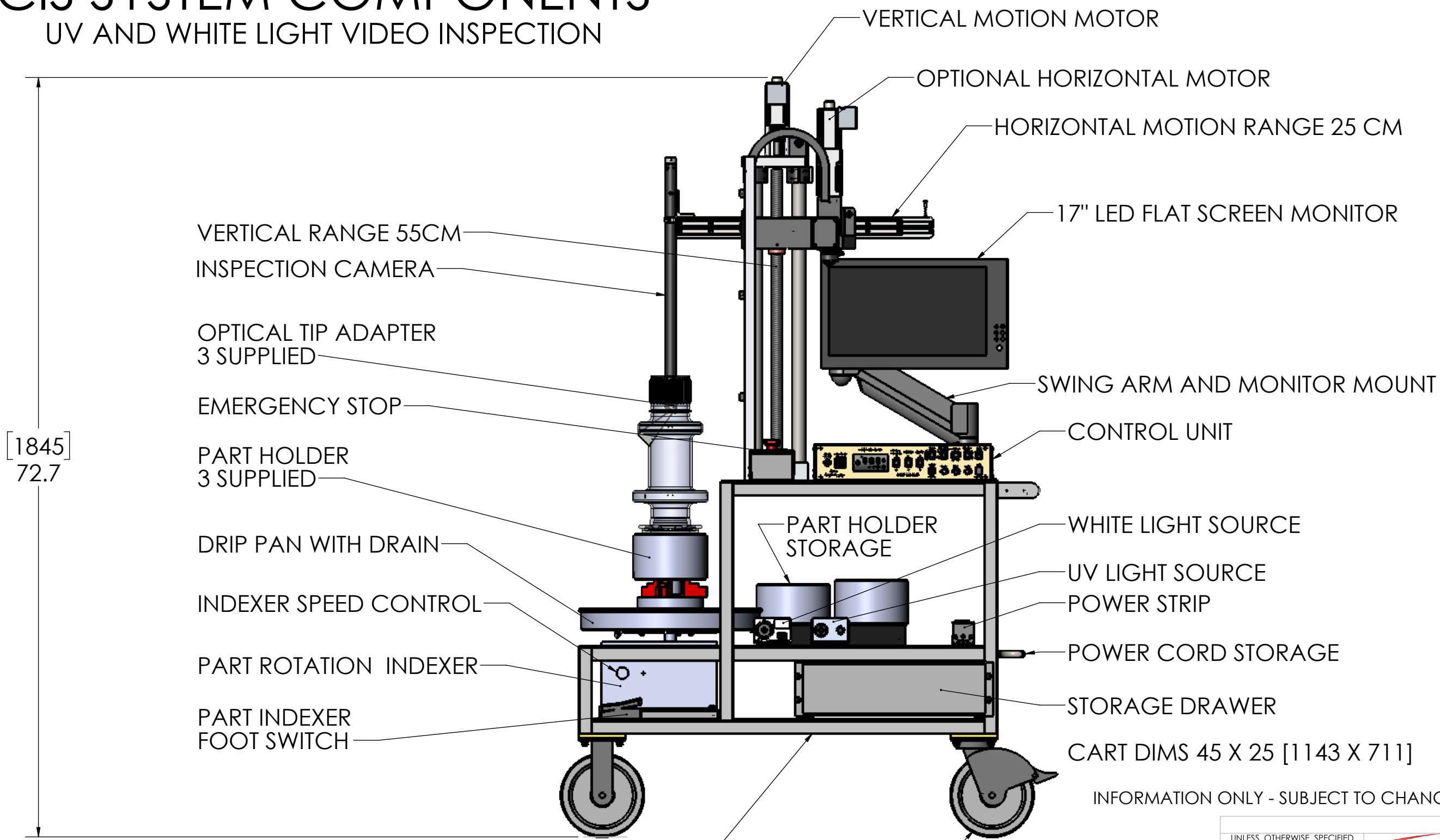

[1845]
72.7

WELDED STEEL CART, BLACK POWDER COAT

HARD WHEELS
TWO CASTER, TWO FIXED

SHEET 1 OF 1

© 2013 InterTest Inc.

PROPRIETARY AND CONFIDENTIAL
THE INFORMATION CONTAINED IN THIS
DRAWING IS THE SOLE PROPERTY OF
INTERTEST, INC. ANY REPRODUCTION
IN PART OR AS A WHOLE WITHOUT THE
WRITTEN PERMISSION OF INTERTEST, INC.
IS PROHIBITED.

UNLESS OTHERWISE SPECIFIED DIMENSIONS ARE IN INCHES		
.XX ±.02	.XXX ±.005	ANGLES ±0° 30'
MATERIAL AS NOTED		
FINISH		
APPROVALS	DATE	
DRAWN WJH	01/18/13	
CHECKED		
CAD FILE:	SCALE	
--	1:10	



P&W COUPLER
INSPECTION SYSTEM

SIZE B 151500 INFO C