



Spellman's XRV series of X-Ray high voltage power supplies sets the standard for compact 1.8kW to 6.0kW, high performance X-Ray inspection generators. Spanning an output voltage range of 160kV to 450kV in negative, positive or bipolar output configurations, there's a model available for virtually every application requirement.

Active power factor correction circuitry reduces input current requirements while minimizing line related EMI. Spellman's proprietary inverter topology allows for unprecedented efficiencies and power densities. A solid encapsulated high voltage section further reduces size and weight and provides reliable, maintenance free operation.

DSP based SMT control circuitry provides your choice of USB, Ethernet and RS-232 along with analog interfacing, simplifying OEM system integration. The two DC output, current regulated filament power supplies are controlled via sophisticated emission current regulation circuitry to provide accurate and stable X-Ray tube currents. Comprehensive fault diagnostic circuitry, and Arc Sense, Arc Quench and Arc Count functionality is also incorporated into this compact, space saving X-Ray generator.

TYPICAL APPLICATIONS

- Non Destructive Testing
- X-Ray Scanning
- Security Applications
- Medical Applications

OPTIONS

- 400Vac $\pm 10\%$ (6kW only)
- GUI Control Software for XRV
- XRVC (XRV Controller)

SPECIFICATIONS

Input Voltage:

1.8kW, 3.0kW, 4.0kW and 4.5kW models:

180-264Vac, single phase, 47-63 Hertz, active power factor corrected input to ≥ 0.98

6.0kW models:

208 or 400Vac, $\pm 10\%$, three phase, 47-63 Hertz, passive power factor corrected

Input Current:

1.8kW, 3.0kW, 4.0kW and 4.5kW models: < 30 amps

6.0kW models: < 25 amps per phase for 208Vac

< 15 amps per phase for 400Vac

NOW AVAILABLE

1800 Watt units specifically designed for the HP and HPX families of X-Ray tubes used in high speed digital and industrial CT applications.

- **160kV, 225kV, 320kV, 350kV and 450kV Models**
- **Complete X-Ray Generator Package**
- **Power Factor Corrected AC Input Circuitry**
- **Integrated Dual Filament Supplies**
- **Digital Interface—USB, Ethernet and RS-232**
- **Excellent Stability and Regulation**
- **Available with Black Powder Coated Finish**

www.spellmanhv.com/manuals/XRV

Output Voltage:

Accuracy: 0.25%

Stability: $\leq 0.1\%$ per 8 hours, after 1 hour warm up

1.8kW, 3.0kW, 4.0kW and 4.5kW models:

Load: $\pm 0.05\%$ of rated output voltage for a full load change

Line: $\pm 0.05\%$ of rated output voltage over specified input voltage range

6.0kW models:

Load: $\pm 0.1\%$ of rated output voltage for a full load change

Line: $\pm 0.1\%$ of rated output voltage over specified input voltage range

Output Polarity:

See "model selection" table

Output Current:

See "model selection" table

Ripple:

See "model selection" table

Temperature Coefficient:

1.8kW, 3.0kW, 4.0kW and 4.5kW models:

± 50 ppm/ $^{\circ}$ C

6.0kW models:

± 50 ppm/ $^{\circ}$ C

Emission Current:

Accuracy: 0.25%

Stability: 100ppm/ $^{\circ}$ C

1.8kW, 3.0kW, 4.0kW and 4.5kW models:

Load: $\pm 0.05\%$ of rated output current for a change from 30% to 100% of rated output voltage

Line: $\pm 0.05\%$ of rated output current over specified input voltage range

6.0kW models:

Load: $\pm 0.1\%$ of rated output current for a change from 30% to 100% of rated output voltage

Line: $\pm 0.1\%$ of rated output current over specified input voltage range

Filament:

Output:

0-6 amps at a compliance of 10Vdc, maximum

Dual Focal Spot:

Small and large, selectable via interface signal

Configuration:

DC filament drive. Closed loop emission control regulates filament setting to provide desired X-Ray tube emission current

Control Interface:

Remote Interface:
Analog, USB, Ethernet and RS-232 are standard
Control Software:
A Windows graphical user interface example is provided.

Environmental:

Temperature Range:
Operating: 0°C to 50°C
Storage: -40°C to 85°C
Humidity:
20% to 85% RH, non-condensing.

Mains Input Connector:

1.8kW, 3.0kW, 4.0kW and 4.5kW models:
Type 97-3102A-24-11P

6.0kW models:
Type 97-3102A-24-22P

Interface Connectors:

Digital—Ethernet, RS-232 and USB
Analog—25 pin connector

Output Connector:

See “model selection” table

Cooling:

Forced air

Regulatory Approvals:

Compliant to EEC EMC Directive/Compliant to EEC Low Voltage Directive, all but 6000 watt unit. NFC 74-100 compliant. UL/CUL recognized, File E227588, all but 6000 watt unit. RoHS Compliant.

GUI Control Software for the XRV



GUI is specifically designed for controlling XRV series power supplies. As an alternative to the analog control, the GUI will allow the user to control all necessary functions of the HVPS from a user-friendly windows based menu. Additionally the GUI can be used as a diagnostic tool when the HVPS is controlled via the analog interface.

- Automatic warm-up of the X-Ray tube
- Max watts operation
- Timed or Continuous Exposure modes
- Configuration menu for user options setting of HVPS
- Fault and status monitor



XRV160/320/350 SPECIFICATIONS

	XRV160*1800	XRV160*3000	XRV160*4000	XRV160*6000	XRV320P&N1800	XRV320P&N4500	XRV350P&N4500
DC Output Voltage	5kV to 160kV	5kV to 160kV	5kV to 160kV	5kV to 160kV	5kV to ±160kV	5kV to ±160kV	5kV to ±175kV
Polarity*	Pos or Neg	Pos or Neg	Pos or Neg	Pos or Neg	Bipolar	Bipolar	Bipolar
Output Rated Current	0-30mA	0-30mA	0-50mA	0-50mA	0-30mA	0-30mA	0-30mA
Output Power	1.8kW	3.0kW	4.0kW	6.0kW	1.8kW	4.5kW	4.5kW
Ripple/Noise (p-p)	<0.025%	<0.05%	<0.1%	<0.25%	<0.025%	<0.1%	<0.1%
Dimensions	10.09" H x 17.16" W x 24" D (256mm x 436mm x 609mm)				2X 10.09" H x 17.16" W x 24" D (256mm x 436mm x 609mm)		
Weight	150 lbs. (68kg)	150 lbs. (68kg)	150 lbs. (68kg)	155 lbs. (70.3kg)	300 lbs. (136 kg)	300 lbs. (136 kg)	300 lbs. (136 kg)
Output Connector	R24	R24	R24	R24	Two R24	Two R24	Two R24

XRV225/450 SPECIFICATIONS

	XRV225*1800	XRV225*3000	XRV225*4000	XRV225*6000	XRV450P&N1800	XRV450P&N4500
DC Output Voltage	5kV to 225kV	5kV to 225kV	5kV to 225kV	5kV to 225kV	5kV to ±225kV	5kV to ±225kV
Polarity*	Pos or Neg	Pos or Neg	Pos or Neg	Pos or Neg	Bipolar	Bipolar
Output Rated Current	0-30mA	0-30mA	0-30mA	0-30mA	0-30mA	0-30mA
Output Power	1.8kW	3.0kW	4.0kW	6.0kW	1.8kW	4.5kW
Ripple/Noise (p-p)	<0.025%	<0.05%	<0.1%	<0.25%	<0.025%	<0.1%
Dimensions	15.90" H x 17" W x 30.72" D (404mm x 432mm x 780mm)				2X 15.90" H x 17" W x 30.72" D (404mm x 432mm x 780mm)	
Weight	240 lbs. (109kg)	240 lbs. (109kg)	240 lbs. (109kg)	240 lbs. (109kg)	480 lbs. (218 kg)	480 lbs. (218 kg)
Output Connector	R28**	R28**	R28**	R28**	Two R28**	Two R28**

Units are available in positive output polarity without filament, see model selection table for ordering details.

*Specify "P" for positive or "N" for negative polarity.

**Order SHV HV cable flange p/n 407141-024 if using Comet HV cable with R28SL spring loaded plug.

J1 HV CONNECTOR — R24/R28

PIN	SIGNAL	PARAMETERS
C	HV Output	XRV160 and XRV320—R24 Connector XRV225 and XRV450—R28 Connector
S	Small Filament Output	0 to 6 amps @ 10Vdc
L	Large Filament Output	0 to 6 amps @ 10Vdc

J2 ANALOG INTERFACE — 25 PIN D CONNECTOR

PIN	SIGNAL	PARAMETERS
1	Power Supply Fault	Low, sum of faults, HVPS detected a fault, open collector, 50V @ 10mA max
2	mA Program	0 to 10V FS Z in = 10M ohms
3	kV Program	0 to 10V FS Z in = 10M ohms
4	Filament Limit L/S Ref.*	0 to 10V FS Z in = 10M ohms
5	Filament Preheat L/S Ref.*	0 to 10V FS Z in = 10M ohms
6	kV Monitor	0 to 10V FS Z out = 4.99k ohms
7	mA Monitor	0 to 10V FS Z out = 4.99k ohms
8	Filament Current Monitor*	0 to 10V FS Z out = 4.99k ohms
9	Signal Ground	Ground
10	X-Ray Enable	+24Vdc = X-Ray ON, connect to pin 14 with dry contact relay
11	Filament ON*	Filament ON status, low, filament is ON open collector 50V, @ 10mA max
12	Interlock 1	Active low, interlock is closed, safe to enable HV
13	Interlock 2	Active low, interlock is closed, safe to enable HV
14	+24Vdc	+24Vdc @ 100mA, maximum
15	Filament Enable*	Active low, turn filament ON
16	Filament Control*	Active low, filament is regulated by ECR (HV must be ON). Not active, the filament is regulated by the preheat reference
17	Filament L/S Select	Filament selection large or small, low = small spot is selected
18	Filament L/S Confirm	Open collector, 50V @ 10mA max Filament selection confirm, low = small spot is selected
19	HVPS RDY	Low = HVPS ready, open collector, 50V @ 10mA max
20	X-Ray ON	X-Ray ON status, low = X-Rays are ON open collector, 50V @ 10mA max
21	Interlock Status	Low, interlocks are closed, can enable HV open collector, 50V @ 10mA max
22	GND	Digital ground
23	X-Ray ON Pre-Warn	Pre-warning, low, before X-Ray ON open collector, 50V @ 10mA max
24	Reset	Active low, minimum 10mS transition
25	Arc fault	Low, arc fault, the HVPS has detected an arc open collector, 50V @ 10mA max

*Not active on positive models

MODEL SELECTION TABLE

MODEL	VOLTAGE	POWER	POLARITY
XRV160*1800	160kV	1.8kW	Pos or Neg
XRV160*3000	160kV	3.0kW	Pos or Neg
XRV160*4000	160kV	4.0kW	Pos or Neg
XRV160*6000/208V	160kV	6.0kW	Pos or Neg
XRV160*6000/400V	160kV	6.0kW	Pos or Neg
XRV225*1800	225kV	1.8kW	Pos or Neg
XRV225*3000	225kV	3.0kW	Pos or Neg
XRV225*4000	225kV	4.0kW	Pos or Neg
XRV225*6000/208V	225kV	6.0kW	Pos or Neg
XRV225*6000/400V	225kV	6.0kW	Pos or Neg
XRV320P&N1800	±160kV	1.8kW	Bipolar
XRV320P&N4500	±160kV	4.5kW	Bipolar
XRV350P&N4500	±175kV	4.5kW	Bipolar
XRV450P&N1800	±225kV	1.8kW	Bipolar
XRV450P&N4500	±225kV	4.5kW	Bipolar

*Specify P for positive polarity and N for negative polarity. Positive polarity models do not have integrated filament power supplies. Contact Spellman for custom output voltage/power models.

RS-232 DIGITAL INTERFACE — J3 9 PIN FEMALE D CONNECTOR

PIN	SIGNAL	PARAMETERS
1	N/C	No Connection
2	TX out	Receive Data
3	RX in	Transmit Data
4	N/C	No Connection
5	SGND	Ground
6	N/C	No Connection
7	N/C	No Connection
8	N/C	No Connection
9	N/C	No Connection

ETHERNET DIGITAL INTERFACE — J4 8 PIN RJ45 CONNECTOR

PIN	SIGNAL	PARAMETERS
1	TX+	Transmit Data +
2	TX-	Transmit Data -
3	RX+	Receive Data +
4	N/C	No Connection
5	N/C	No Connection
6	RX-	Receive Data -
7	N/C	No Connection
8	N/C	No Connection

USB DIGITAL INTERFACE — J5 4 PIN USB “B” CONNECTOR

PIN	SIGNAL	PARAMETERS
1	VBUS	+5 Vdc
2	D-	Data -
3	D+	Data +
4	GND	Ground

JB1 MAIN AND AUXILIARY INPUT POWER — TYPE 97-3102A-24-11P (Single Phase Units)

PIN	SIGNAL	PARAMETERS
A	Auxiliary AC Line Power	180-264Vac
B	Auxiliary Ground	Ground
C	Auxiliary AC Neutral	Neutral
D	Main AC Line Power	180-264Vac
E	Main Ground	Ground
F	Main AC Neutral	Neutral

JB1 MAIN AC INPUT POWER — TYPE 97-3102A-24-22P (Three Phase Units)

PIN	SIGNAL	PARAMETERS
A	Line 1	208Vac, ±10%, 50/60Hz @ 25 amps
B	Line 2	208Vac, ±10%, 50/60Hz @ 25 amps
C	Line 3	208Vac, ±10%, 50/60Hz @ 25 amps
D	GND	Ground

Note: Use 4 conductor cable or single isolated wires rated no less than 600Vac, 30 amps (10AWG, minimum)

JB2 AUXILIARY AC INPUT POWER — TYPE 97-3102A-20-3P (Three Phase Units)

PIN	SIGNAL	PARAMETERS
A	Line 1	208Vac, ±10%, 50/60Hz (source 3 phase L1, L2)
B	Line 2	208Vac, ±10%, 50/60Hz (source 3 phase L1, L2)
C	GND	Ground

System Ground: System ground wires (10AWG minimum) to the ground terminal E1 GND to the power supply using ground stud M6 X 20MM, with M6 nut.

XRV160
TOP VIEW

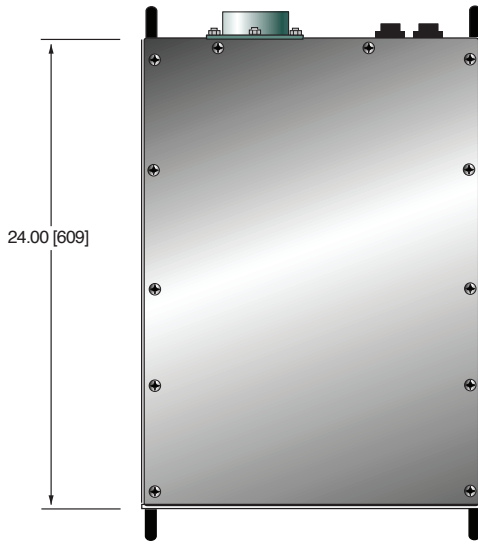

FRONT VIEW

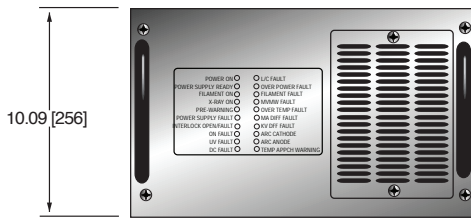

REAR VIEW

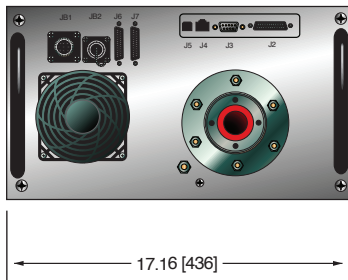

XRV320 is comprised of two XRV160 units configured in a bipolar arrangement

DIMENSIONS: in.[mm]

XRV225
TOP VIEW

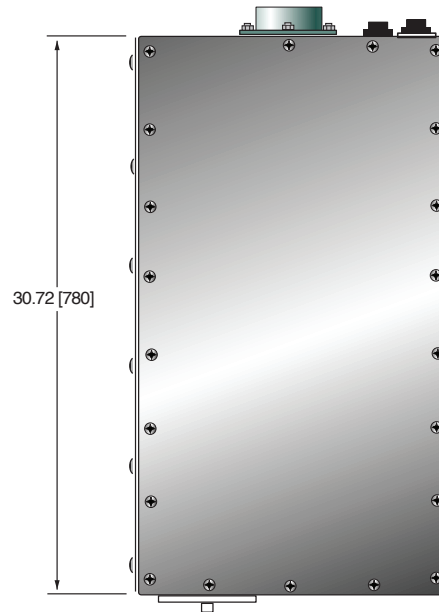

FRONT VIEW

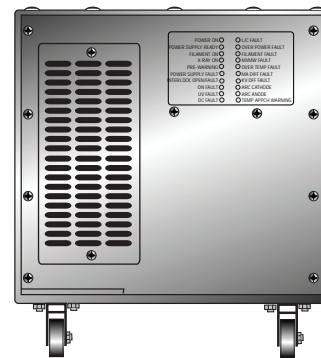

REAR VIEW

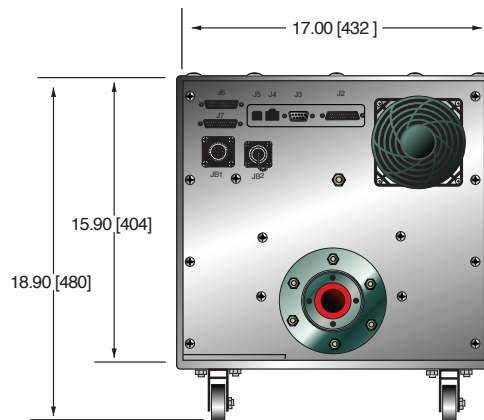

XRV450 is comprised of two XRV225 units configured in a bipolar arrangement

